

# VEGAPULS SR 68

## Foundation Fieldbus

### Radar sensor for continuous level measurement of bulk solids



#### Application area

VEGAPULS SR 68 is designed for level measurement of bulk solids even under the most difficult process conditions. Its mechanical construction and electronics are specially optimised for such applications. Many application possibilities can be found in the food processing industry, in plastics processing and steel production as well as in the building industry.

#### Advantages

- Non-contact measurement
- Simple mounting
- Wear and maintenance free
- Unaffected by pressure, temperature, gas and dust
- High accuracy
- SIL qualified

#### Function

Extremely short microwave impulses are emitted by the antenna system in the direction of the measured product, reflected by the product surface and received back again by the antenna system. The time from emission to reception of the signals is proportional to the level.

A special processing procedure ensures reliable and precise measurement.

#### Technical data

Measuring range up to	30 m (98.43 ft)
Deviation	±2 mm
Process fitting	Thread G1½ A or 1½ NPT, flange from DN 50 or ANSI 2"
Process pressure	-1 ... +100 bar/-100 ... +10000 kPa (-14.5 ... +1450 psig)
Process temperature	-40 ... +250 °C (-40 ... +482 °F)
Ambient, storage and transport temperature	-40 ... +80 °C (-40 ... +176 °F)
Operating voltage	9 ... 32 V DC

#### Materials

The wetted parts of the instrument are made of 316L resp. PTFE or PEEK. The process seal is made of FKM or FFKM. You will find a complete overview of the available materials and seals in the "configurator" on our homepage under [www.vega.com/configurator](http://www.vega.com/configurator).

#### Housing versions

The housings are available as single chamber or double chamber version in plastic, stainless steel or aluminium. They are available in protection ratings up to IP 68 (1 bar).

#### Electronics versions

The instruments are available in different electronics versions. Apart from the two-wire electronics with 4 ... 20 mA/HART, a four-wire version and two purely digital versions with Profibus PA and Foundation Fieldbus are available.

#### Approvals

The instruments are suitable for use in hazardous areas and are approved, for example, according to ATEX. You can find detailed information on the existing approvals in the "configurator" on our homepage under [www.vega.com/configurator](http://www.vega.com/configurator).

## Operation

The adjustment of the instrument is carried out via the optional indicating and adjustment module PLICSCOM or via a PC with the adjustment software PACTware and respective DTM. Another adjustment possibility is a configuration tool for Foundation Fieldbus instruments.

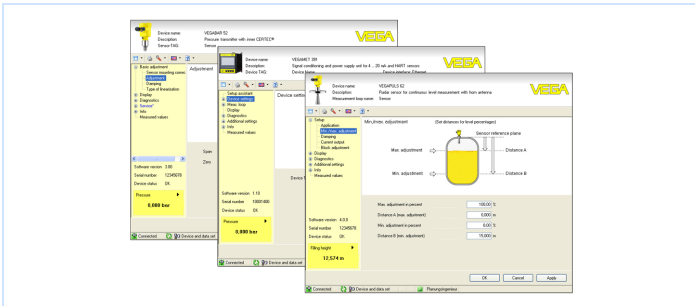
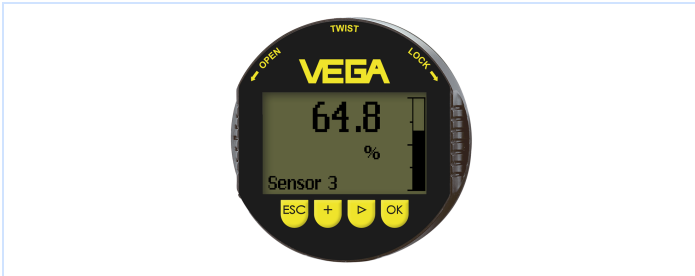

## Electrical connection

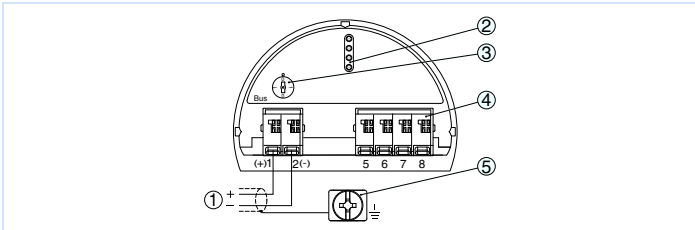

Electronics and connection compartment, single chamber housing

- 1 Voltage supply/Signal output
- 2 Contact pins for the indicating and adjustment module or interface adapter
- 3 Simulation switch ("1" = mode for simulation release)
- 4 For external indicating and adjustment unit
- 5 Ground terminal for connection of the cable screen

You can find details on the electrical connection in the operating instructions of the instruments on our homepage under [www.vega.com/downloads](http://www.vega.com/downloads).

## Dimensions

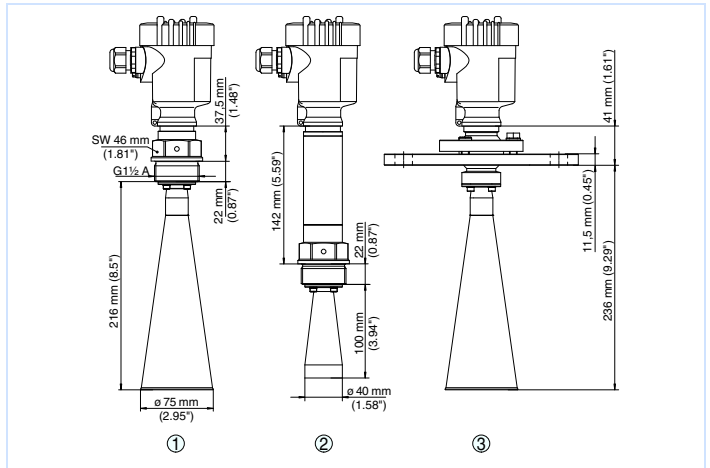

Dimensions VEGAPULS SR 68

- 1 Threaded version
- 2 Threaded version with temperature adapter
- 3 Flange version with swivelling holder

## Information

You can find further information about the VEGA product line on our homepage [www.vega.com](http://www.vega.com).  
In the download section under [www.vega.com/downloads](http://www.vega.com/downloads) you'll find free operating instructions, product information, brochures, approval documents, instrument drawings and much, much more.  
There, you will also find GSD and EDD files for Profibus PA systems as well as DD and CFF files for Foundation Fieldbus systems.

## Instrument selection

With the "finder" you can select the most suitable measuring principle for your application: [www.vega.com/finder](http://www.vega.com/finder).  
You can find detailed information on the instrument versions in the "configurator" on our homepage under [www.vega.com/configurator](http://www.vega.com/configurator).

## Contact

You can find the VEGA agency serving your area on our homepage [www.vega.com](http://www.vega.com).