



# MOBILE SHIPLOADERS

**B&W**

**AUMUND GROUP**



Port of Par

## GENERAL APPLICATIONS

The most comprehensive range of mobile Shiploader systems available with special features designed to speed vessel loading handling the complete range of dry bulk cargoes at rates up to 2,000 tons per hour.

Full Function Mobile Shiploaders offer a cost effective and fast track solution with complete flexibility.

By combining the benefits of the Samson™ Receiving Unit plus comprehensive options of travel systems and trimming equipment the B&W Mobile Shiploader offers the level of performance normally associated with fixed installations but with complete flexibility.

Since no special civil works are required the Mobile Shiploader may operate on any suitable existing quay area or river berth using existing infrastructure thus drastically reducing the capital cost of a new export facility with the further benefit of fast track availability.

The flexibility and fast track availability offered by mobile equipment allows the port operator to react to changing market conditions taking advantage of often short term contracts. In a rapidly changing export commodity market, the Mobile Option may be confidently selected in the knowledge that the equipment may be easily relocated or even resold if a contract is terminated.

The strong second-hand market for these machines guarantees excellent

residual values thus minimising the investment risk associated with any project however volatile the market conditions may be.

On the front cover operating at the Port of Dundee the mobile Shiploader with independent multi-entry Samson™ feeders loading cereals to Handy size ships at rates up to 1,000 t.p.h. and in this application includes a variable speed radial thrower for trimming the vessel hold.



Port of Runcom

## GENERAL APPLICATIONS

The comprehensive optional design features offered in the **B&W** range allows operators to choose the precise specification required for a particular application.

**Port of Par:** Loading Kaolin at the Port of Par this full function machine includes In-Line and Parallel manoeuvring systems with Twin Samson™ receiving units mounted to the chassis. A “Cascade” trimming chute provides dust-free loading to the vessel hold. The twin Samson™ units allow fast truck handling giving a peak rate loading capacity of over 1,000 tons per hour.

**Port of Runcorn:** Loading refined Salt to vessels up to 10,000 DWT for Salt Union including a single mounted Samson™ feeder plus a variable angle trimming chute with radial distributor, full powered travel is provided with In-Line and Parallel motion.



Port of Kings Lynn

**Port of Kings Lynn:** A basic design with cambered boom and wide tipping hopper suitable for receiving free flowing materials such as grains and fertilisers direct from the truck using the small “Grain Door”. Shown here with a Radial Trimming Chute including Infra-Red remote control.

**Port of Augusta:** Loading Sulphur this machine is supplied with a straight pattern outloading boom and includes both In-Line and Parallel travel Powered Manoeuvring equipment. A single Samson™ on a slew ring mount receives the material direct from tipping trucks and a variable angle trimming chute is provided with radial chute also.



Port of Augusta

# SHIPLOADER OPTIONS

The ultimate solution for inclined boom designs available in an extended range of boom lengths and with comprehensive trimming, feeder and manoeuvring systems suitable for loading vessels through to Panamax at very high handling rates.

Belt Widths  
- 1000, 1200 or 1400 mm.

Handling Rates to 2,000 t.p.h.

All B&W outloading boom designs include integral three roll troughing idlers to support the conveyor belt formed into the structure design for maximum rigidity and minimum weight.

The designs illustrated here show the most popular range of machine configurations for typical Ship Loading applications from small barges and coasters through to Panamax or even Cape Size vessels using the Sterling Series.

For special applications B&W offer a bespoke design service to satisfy the requirements of particular projects or berths.

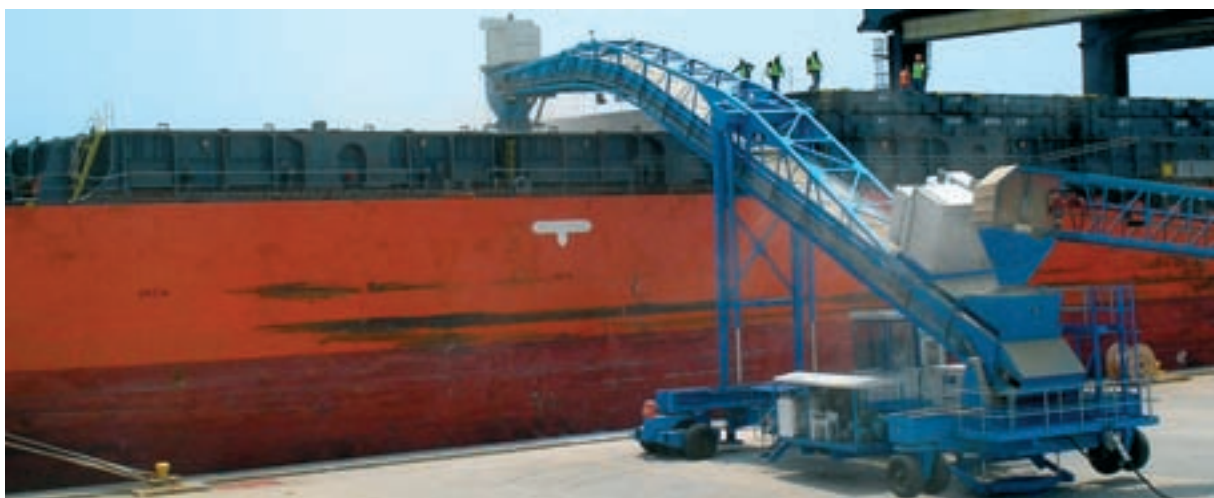
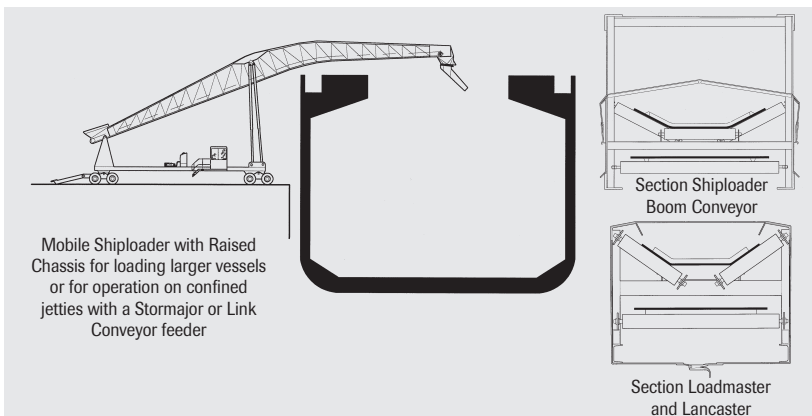
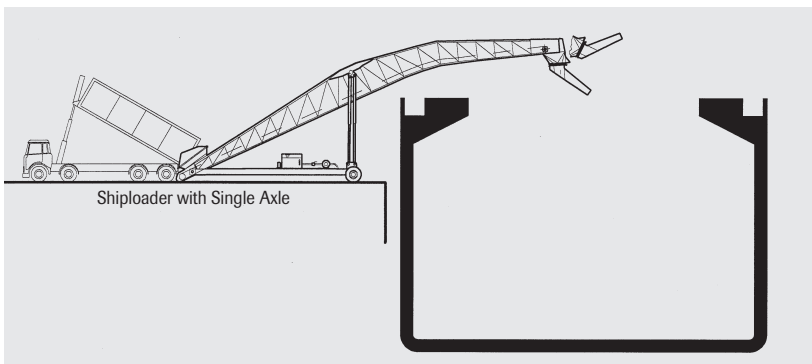
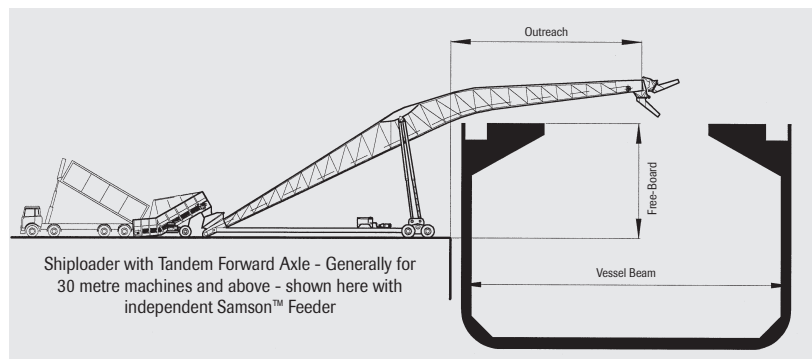

Shiploader with Radial Travel fed via Link Conveyor.

## DESIGNS AND DIMENSIONS

Machine Type	Length	Outreach	Free-Board	Beam
Shiploader	18 m	7 m	5.5 m	14 m
Shiploader	21 m	8.5 m	6.1 m	16 m
Shiploader	23 m	9.5 m	5.7 m	17 m
Shiploader	25 m	10.5 m	6.5 m	18 m
Shiploader	27 m	11.5 m	7.6 m	18 m
Shiploader	30 m	13 m	8.4 m	20 m
Shiploader	35 m	15 m	9.7 m	25 m
Shiploader	40 m	17.5 m	11.2 m	30 m
Shiploader	45 m	20 m	12.3 m	32 m
Shiploader	50 m	22.5 m	13.7 m	35 m
Shiploader	55 m	25 m	14.8 m	40 m
Shiploader	60 m	27.5 m	15.8 m	40 m

The table of dimensions is based on a machine operating angle of 25 degrees using the maximum outreach as specified for each machine size. Alternative configurations are possible for particular applications and increased working angles are available for some materials.



Samson™ mounted on slewing frame to Shiploader chassis.



Shiploader operating on a Narrow Quay



Raised chassis Shiploader with Stormajor feeder.



Twin integral Samson™ feeders mounted to the Shiploader chassis

## INTEGRAL SAMSON™ FEEDERS

The Samson™ provides a buffer holding capacity storing the material between truck deliveries to provide a constant discharge to the outloading boom.

In this manner trucks may be rapidly discharged and the overall handling rate of the installation optimised to increase the average loading rate to the vessel.

The Samson™ Apron Belt Feeder represents a major feature in the application of Mobile Shiploaders allowing virtually any dry bulk cargo to be received direct from tipping trucks without the need for permanent civil works.

By mounting the Samson™ (either singly or in pairs) to the Shiploader chassis the complete equipment may be moved as a single integrated unit.

Each Samson™ is mounted to a pivot shaft at the head and supported on

twin hydraulic cylinders allowing the complete machine to be raised clear of the quay surface for manoeuvring.

Automatic feed rate control systems meter the material delivery to the outloading boom to maintain maximum loading rate without fear of overload.



Buffer holding capacity within the Samson™ feeder



Twin Integral Samson™ receiving units allow two trucks to be discharged simultaneously to maximise the system handling rate and minimise the effect of delays in vehicle positioning.

As illustrated below a single Samson™ Unit is mounted to the Shiploader on a Slewing Ring allowing alignment in any direction for maximum flexibility in congested quay areas.

The Samson™ may be raised clear of the quay surface for positioning and for machine manoeuvring using the powered travel system.



Shiploader with Twin Samson™ loading Panamax Vessel

## SAMSON™ FEEDERS MOUNTED TO THE SHIPLOADER CHASSIS



Slew Ring Mount allows the Samson™ to be positioned through 180 degree working arc



Samson™ raised for travelling

## INDEPENDENT SAMSON™ FEEDERS



Twin Feeders provide fast truck turnaround

Twin mobile Samson™ units are handling cereals using a forward facing centralising chute system allowing the machines to be positioned at an angle to the Shiploader.

This arrangement is only possible handling free-flowing materials. For non-free-flowing materials the machines must be positioned directly opposite each other.

Drive to the Samson® may be either from an independent electric or diesel motor mounted to the Samson™ or taken from the Shiploader drive unit using a flexible hydraulic connection.



Twin independent Multi-Feed-Point Samson™ feeders discharge to a single Shiploader

## THE MOBILE SAMSON™ FEEDING A SHIPLOADER

Using an extended Multi-Feed point loading section the Samson™ may receive from up to five trucks simultaneously.

This arrangement is suitable only for free flowing materials but offers very high average loading rates allowing the Shiploader output to be maintained continuously eliminating any delays whilst vehicles are positioned.



Up to four trucks discharge simultaneously per Samson™ feeder

## ALTERNATIVE FEEDER SYSTEMS

Alternative feeder arrangements offer an economical alternative where the benefits of the Samson™ are not necessary.

The Shiploader may be supplied with direct tipping hoppers where the material specification permits and trucks are available with the small grain door discharge system allowing a controlled feed rate from the truck to the Shiploader.

Twin Feeder conveyors permit greatly increased handling rates since two trucks may be handled simultaneously eliminating down time whilst the truck is manoeuvred to the equipment.

Feeder conveyors may be mounted to the Shiploader chassis forming an integrated design where machines are supplied with powered travel systems.

Drive to the feeder may be by simple electric motor or hydraulic power transfer from the Shiploader diesel motor.

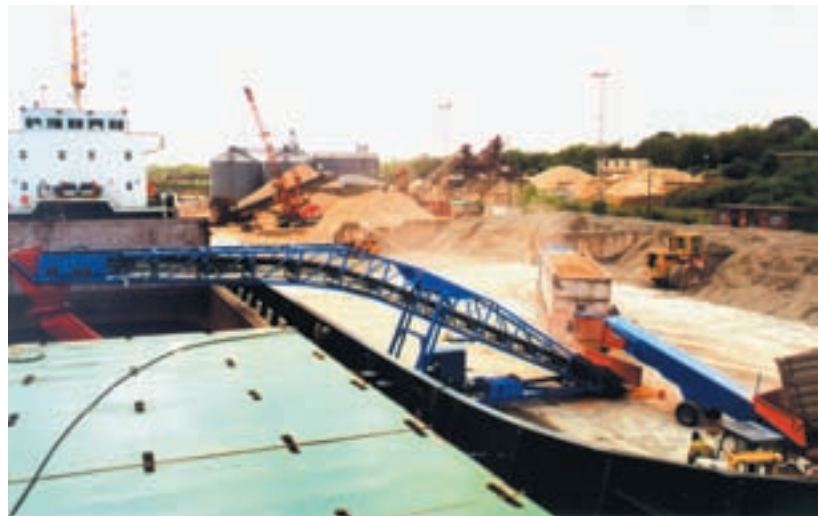

Feeder Conveyors discharge to the Shiploader

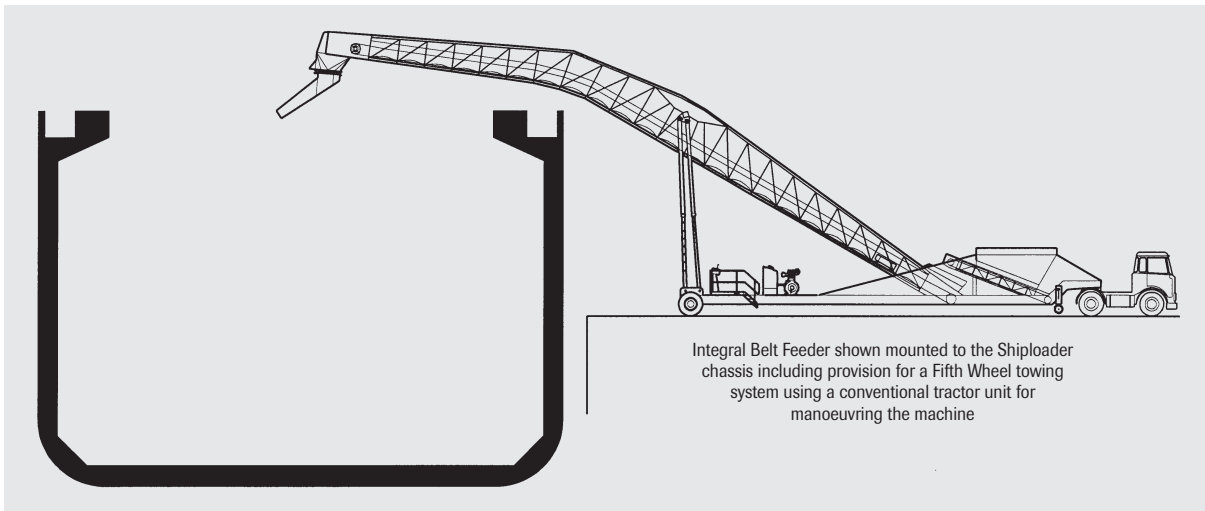

Integral Belt Feeder shown mounted to the Shiploader chassis including provision for a Fifth Wheel towing system using a conventional tractor unit for manoeuvring the machine

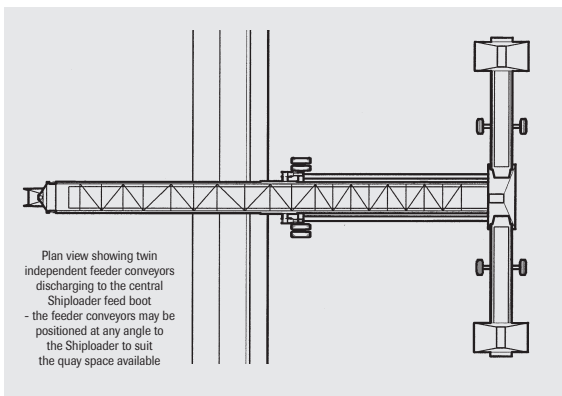

Plan view showing twin independent feeder conveyors discharging to the central Shiploader feed boot - the feeder conveyors may be positioned at any angle to the Shiploader to suit the quay space available

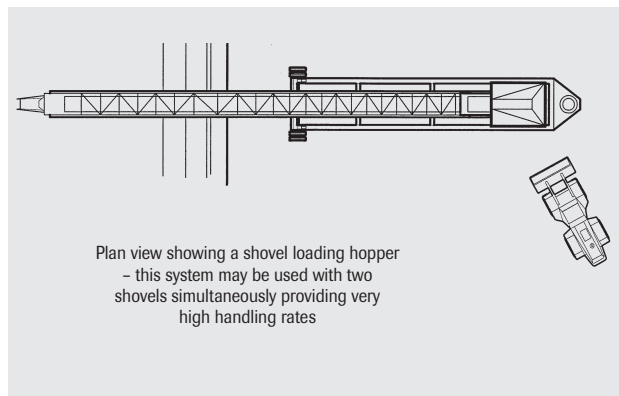

Plan view showing a shovel loading hopper - this system may be used with two shovels simultaneously providing very high handling rates

**Direct Truck Loading:** Tipping Hoppers offer an economical solution for handling free flowing materials which may be discharged from the truck through the small "Grain Door".

Using the direct loading hopper and a combination of feeder conveyors increased loading rates are possible handling materials such as cereals, oil seeds, fertilisers etc. with the flexibility to discharge two or even three vehicles simultaneously.

**Direct Shovel Loading:** Using a Steep Side hopper with a Loading Shovel allows direct loading for non-free-flowing materials mounted direct to the Shiploader. This arrangement is not generally suitable for abrasive materials where a separate belt feeder is the preferred solution.



Tipping truck discharging direct to Mobile Samson™ Feeder - No Ramps Required

**Belt Feeders:** An economical solution to the handling of most material types from Tipping Trucks or Loading Shovels at high handling rates with the flexibility

to position the feeder parallel to the vessel to reduce the total quay space required.



In-Line Powered Travel with Rear Steering Axles and Twin Tandem Front Axle

## COMPREHENSIVE MANOEUVRING CONTROL

Powered Travel speeds machine positioning for easy trimming and improved overall loading rate

Variable speed hydraulic driving systems with hydraulically operated steering provides effective control with safety when moving larger equipment.

Hydraulically released oil immersed disk type fail-safe brakes are automatically engaged when the control lever is released.



Four wheel pivoting axle assembly



Integral Hydraulic Hub Motor



New Generation Wheel Alignment



Twin Tandem Main Axle



Powered Radial Operation with In-Line Tow Travel



Parallel & Inline Powered Travel with Samson™ Castors



Forward Axle Beam with Telescopic Boom Supports



Parallel and In-Line Powered Travel

# POWERED TRAVEL SYSTEMS

Using the “New Generation” axle mounting comprehensive powered travel options are available.

The New Generation design comprises a pair of wheel units mounted to a slewing ring with a hydraulic actuator. Powered travel is provided by integral hydraulic motor units within the wheels driven and controlled from the central hydraulic system. For larger machines Twin Tandem axles are provided with up to eight wheels on the forward axle and including jacking cylinders to raise the chassis to permit wheel realignment without excessive stress to the tyre walls.

**Parallel Travel:** New Generation wheel positioning units are fitted to both the forward and rear axles allowing each set of wheel units to be aligned for In-Line and Parallel travel plus Crab travel. To maintain accurate wheel positioning automated systems are available with a rotary potentiometer mounted to each wheel unit plus an electronic comparator circuit to guarantee correct alignment for any chosen mode of operation.

**Radial Travel:** Using a New Generation forward axle design Radial travel is possible with the option of In-Line and Parallel combined together in any format to suit the required operational parameters.

**In-Line Travel:** A fixed forward axle with steering only provided at the tail section using an Ackerman linkage and hydraulic actuators.

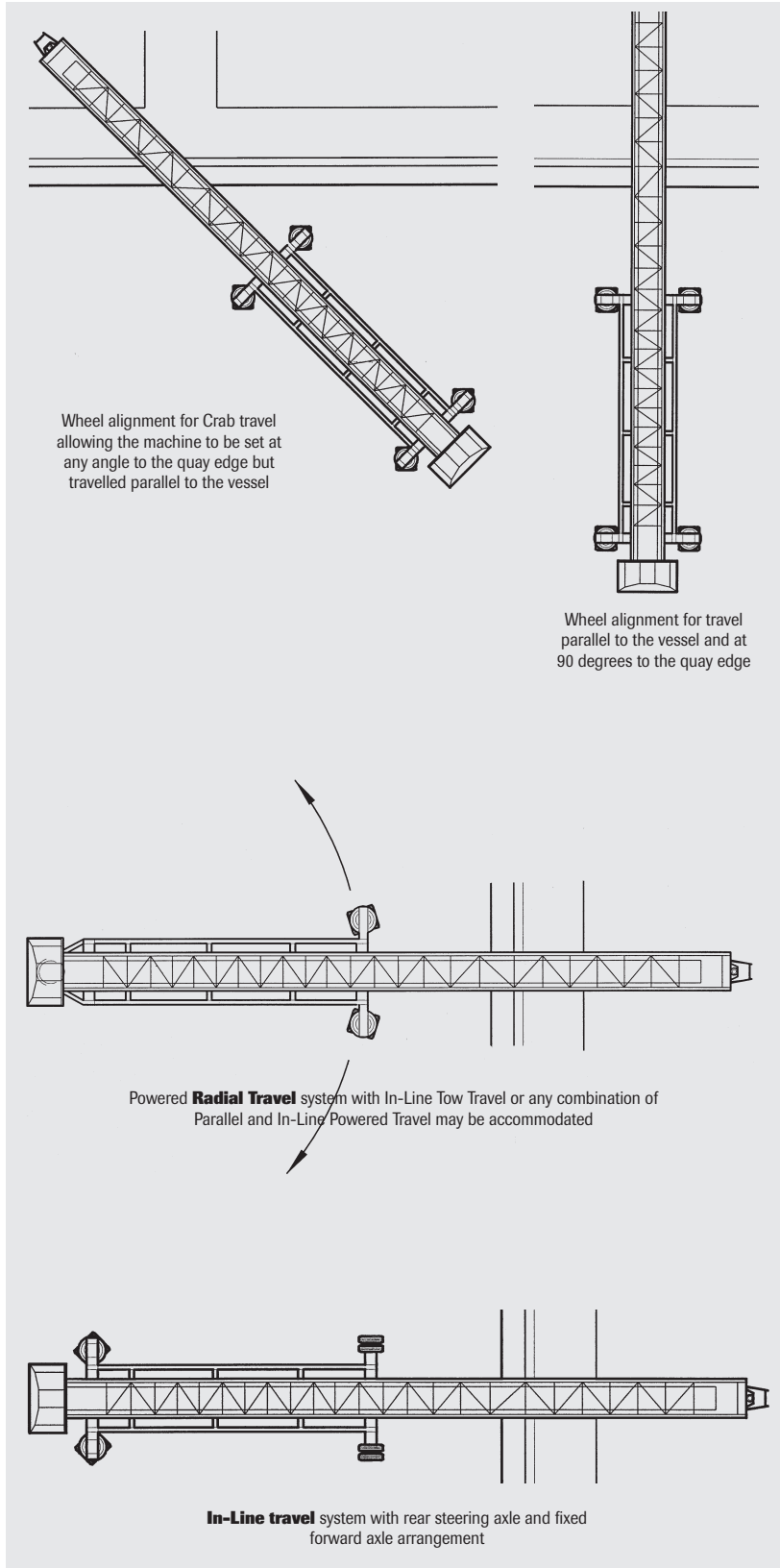

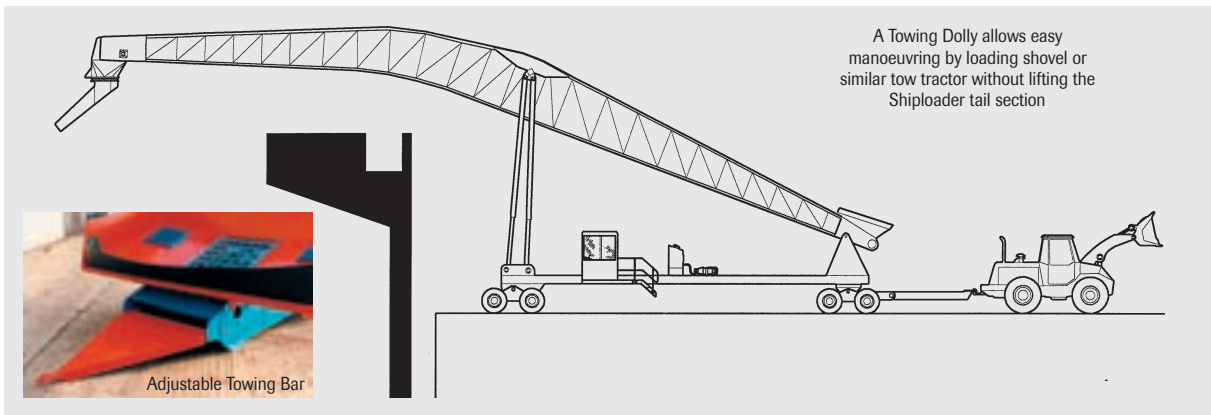

## TOW TRAVEL SYSTEMS

Tow travel offers an economical solution for general machine movements.

Using the standard adjustable towing bar smaller machines may be easily moved using a fork lift truck or similar system to lift and tow the complete unit.

For larger machines, a towing dolly allows easy and safe movement without lifting the tail section.

The further option of a Fifth Wheel coupling as shown on page 9 allows direct towing by truck or a towing dolly for maximum flexibility.

Radial and Parallel tow travel options are also possible using a conventional agricultural tractor to tow or push the machine with the option of castor wheels to the tail section where the quality of the quay surface permits.



Tractor Tow Travel



Tail end Castor-Wheel mounts with Parallel Push Travel



For these applications a simplified wheel alignment system may be utilised incorporating a pivoted stub axle and hydraulic actuator as shown below with the further option of braked wheels or safety jacks to prevent runaway.



Stewing Stub Axles

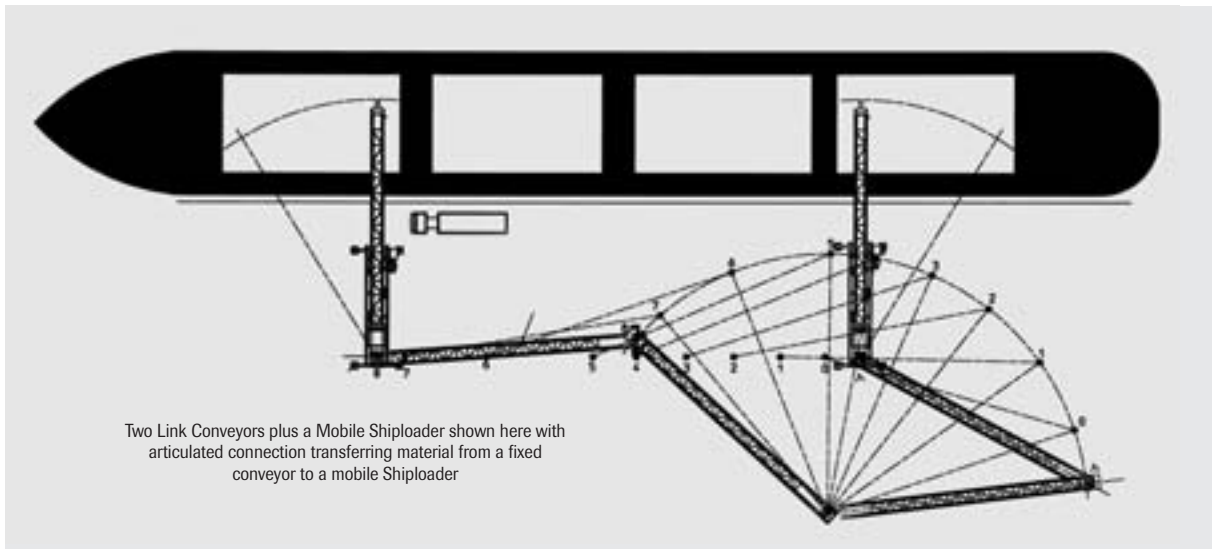

Two Link Conveyors plus a Mobile Shiploader shown here with articulated connection transferring material from a fixed conveyor to a mobile Shiploader

## LINK CONVEYOR MATERIAL TRANSFER SYSTEMS

Independent Fixed length or Telescopic Link Conveyors are the ideal solution where a fixed loading point is required.

The Link Conveyors may be operated in pairs or extended with additional units to convey material from a fixed loading point to a Mobile Shiploader allowing flexibility to load to all the vessel holds and trim each hold with minimum lost time.

For larger units self propelled or towing dolly options are available and where high manoeuvrability is required the Link Conveyor may be supplied with In-Line and Parallel travel systems as shown opposite.

Smaller machines may be supplied with a central axle and a towing bar for movement on the quay.

Drive to the Link Conveyor may be from shore based electric power, individual diesel engine or it may be linked direct to the main Shiploader diesel Gen-Set drive for complete system autonomy.

Full instrumentations integration is also available for fully sequenced starting and safety systems.



Link Conveyors with Powered Travel and Full Manoeuvring Facilities



Shiploader with New Generation movement fed via Telescopic Link Conveyor



Full specification mobile Shiploader with a Variable Angle Trimming Chute and Radial Distributor

## VESSEL TRIMMING SYSTEMS

Effective Ship Trimming is an essential requirement for fast and efficient Ship Loading.

A comprehensive range of Trimming Options are available for all Mobile Shiploaders with either manual or electrical control systems for complete flexibility.

The variable angle chute system as illustrated opposite allows the complete chute to be raised up clear of the vessel for machine positioning.

All Trimming Chutes are available with radio or infrared remote control systems permitting operation from the vessel deck.

Two stage variable angle and telescopic trimming chutes including a rotating distributor

allow accurate material placement within the vessel hold.

Telescopic chutes eliminate the effect of cross winds on the material inflight to reduce cargo losses and pollution and when combined with variable angle control improve the hold trimming range.



Two stage variable angle and telescopic trimming chute



Sticky materials illustrated above loading peat and FGD Gypsum below



Radial Thrower provides effective trimming with minimum machine movements

## THROWERS AND CHUTE DISTRIBUTORS

All power operated Trimming systems are offered with the option of Infrared or Radio remote control allowing the operator to control the material placement within the hold from the vessel deck using a hand held press button controller.

Radial Thrower mounted to a three stage telescopic chute system provides excellent flexibility for trimming free flowing materials. With a trajectory of 20 metres a complete hold may be trimmed without moving the main Shiploader. Using remote variable speed control the trajectory may be easily adjusted allowing accurate material placement within the vessel hold.



Rotating Variable Angle Chutes offer an economical solution with accurate trimming capability





Full Specification Shiploader handling Cement Clinker to Handy Size Ships

## POLLUTION CONTROL SYSTEMS

Comprehensive Mobile Shiploader operating in the Port of Gizan (Saudi Arabia) handling Cement Clinker both from very large loading shovels or direct from dump trucks.

In this installation an In-Line Samson™ feeder unit with levelling blade provides a controlled feed rate to the Shiploader boom conveyor handling 1,100 tons per hour.

A full profiled steel enclosure is fitted to the Samson™ with Reverse Jet Dust Filter unit above including maintenance access platform.

At the feed boot of the boom conveyor a second Dust Filter is provided to fully control dust generation at the transfer point.

Drive to the complete machine is provided from a Diesel Gen-Set mounted to the machine chassis with electro-hydraulic power transfer and including an on-board air compressor to operate the reverse jet cleaning cycle.

Dust control is critical handling this type of material to minimise environmental pollution. In these circumstances the Mobile Shiploader is available with an extensive range of pollution control facilities integrated to the design.



Telescopic Cascade Trimming Chute to control dust emissions from the outloading boom head to the hold floor including an automatically controlled electric winch to raise and lower the chute to follow the cargo profile.



Twin Samson™ Feeders with Flexible Enclosures

## ENCLOSURES AND DUST CONTROLLED CHUTES

The Telescopic Cascade Trimming Chute controls the material velocity from the outloading boom head to the hold floor to prevent particulate separation and dust generation.

Comprising a stack of inclined cones the Cascade device constrains the material flow in a Zigzag pattern to limit the flow velocity.

As shown on Page 17 the system is supplied with an external flexible cover to enclose the material path preventing wind blown dust generation.

In addition a rotating distributor is also available to provide ship trimming capability comprising a chute mounted to a slew ring with an electric motor drive unit.

Combined with the dust control features illustrated the Cascade system permits the handling of very dry and dusty material with minimum environmental pollution.

By significantly reducing dust generation, extraction systems may either be eliminated completely or sized at an economical level for extremely sensitive applications.



Shiploader with Enclosed Boom and Telescopic Free Fall Chute

Flexible PVC covers for the Samson™ feeder units and the Outloading Boom Conveyor offer economical and effective dust control.

The receiving action of the Samson™ design effectively draws material from the truck minimising material drop and virtually eliminating dust generation at the truck tipping point.



Rotating Distributor



## DIESEL GEN-SET DRIVES



Diesel Gen-Set drives the complete Shiploader and Feeders



Auxiliary Gen-Set Drives the Powered Travel System Only



Combined Gen-Set and electric drive

A comprehensive range of drive systems are available tailored to the requirements of each application.

**Diesel Power:** As shown opposite diesel drives are available using either the air cooled engines or for high power application to 500 kW, the Perkins (Caterpillar) range of liquid cooled engines are offered.

For the Mobile Shiploader design the engine is mounted to the main chassis at low level for easy access and maintenance. To satisfy ever more stringent environmental noise pollution demands all engines are available with a sound attenuated enclosure designed for an 80 dba sound pressure level at 1.0 metre from the machine.

**Electric Power:** Where shore power is available, electric motor drives offer an economical and minimum maintenance solution using a trailing cable between the power supply and the Shiploader.

**Diesel/Electric Power:** The machines illustrated top and bottom on this page are fitted with Diesel Powered Gen-Set drives comprising an engine/generator unit installed within a sound attenuated enclosure mounted directly to the Shiploader chassis at low level.

The bottom illustration shows a combined Gen-Set and Electric powered machine with a trailing cable allowing operation from the shore supply where available or from the Gen-Set where no shore power is available. Note the cable drums fitted in front of the main axle to store the umbilical cable when not required.

**Electric + Diesel Power:** Where shore power is available but machines have to be driven off the berth outside the range of flexible cables, an electric drive system may be installed for the main conveyor and feeder drives with a smaller Diesel power unit to drive the powered travel system exclusively.



Electric or Diesel Hydraulic Drive

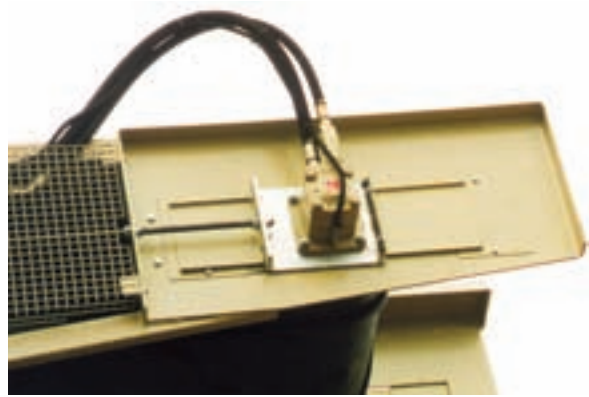

Integral Hydraulic Motor Drive to the Head Pulley

## DIESEL AND ELECTRO-HYDRAULIC DRIVES



Axial Piston Pump



Radial Piston Motor



Deutz Diesel motor



Hydraulic drive systems allow high power transmission capacity with compact installation driving the conveyor head pulley for maximum drive traction and minimum belt tension.

Highly developed hydraulic drive systems with either electric or diesel prime movers allow complete flexibility in the machine design with maximum reliability and minimum maintenance.

By direct coupling both the pump and motor accurate alignment is guaranteed. Using high torque hydraulic motors eliminates the need for reduction gears and allows remote mounting on the conveyor head with no need for maintenance access.

Using multiple pump units for machines fitted with powered travel systems and integral feeder equipment allows each pump/motor combination to be individually selected for the required duty.

## CABINS AND CONTROLS

An extensive range of control options are available from simple manual lever valves through to complex PLC validated integrated control systems.

The control systems illustrated are tailored to the requirements of each application depending upon the scope of facilities included. In addition to the machine operator's controls Infrared or Radio Remote control systems are also available for the operation of trimming systems from the vessel deck.

For complex machines PLC validation is provided integrated to the on-board instrumentation with a preprogrammed range of operating modes to minimise operator intervention.



For less complex machines, simple chassis mounted panels are supplied or basic hydraulic lever valves for the entry level specifications.



Operator's Control Cabin raised above the Forward Axle



Full Operator's Control Desk with Joy-Stick Steering System



# INSTRUMENTATION

Comprehensive instrumentation provided both for the automatic operation of control functions and for the safety and protection of the operators and mechanical equipment.

The illustration with Twin Samson™ Feeders typifies the larger integrated designs where automated operation is employed to gain the maximum performance from the systems with the minimum of operator intervention.

Auto-Feed-Rate controls permit random loading to each Samson™ feeder unit by controlling the Samson™ output rate to maximise the available handling rate on the outloading boom conveyor. Each Samson™ may be rated at the full capacity of the outloading boom to maximise performance without risk of overloading.

For machines with multiple travel modes, Electronic Ackerman Steering is provided with rotary potentiometers fitted to each steering unit linked to the central PLC to fully automate wheel alignments in any travel direction.



Protection systems are provided to prevent damage to the sensitive hydraulic components monitoring fluid pressure, temperature and levels using instruments linked to the central PLC system.

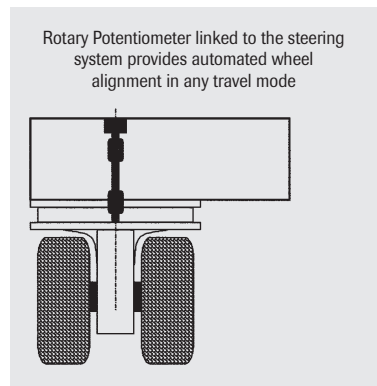
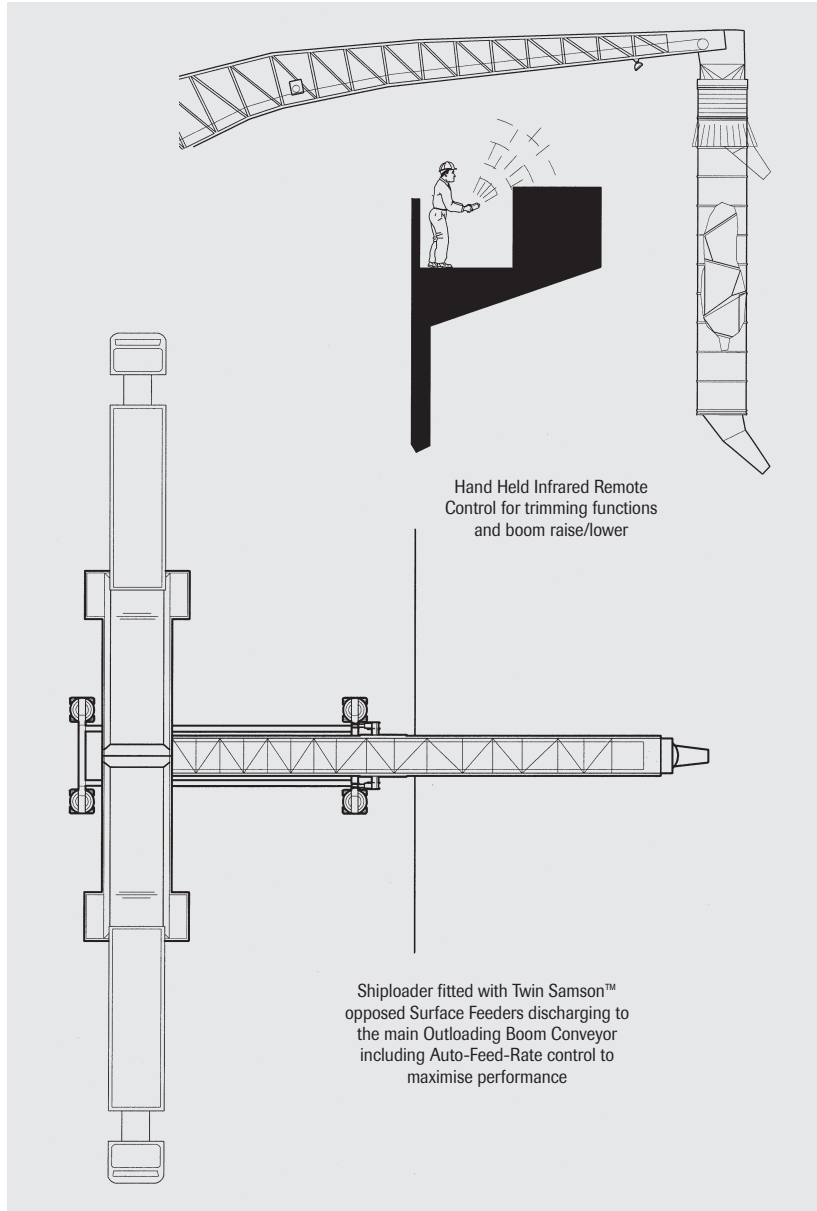

## AFTER SALES SERVICE

B&W Mechanical Handling Ltd., within the Aumund Group, strive to deliver the highest standards of customer support and after sales service worldwide with the collaboration of the local Aumund Group daughter companies and representative offices and including: -

- Application advice.
- Conceptual Plant Layout.
- Plant Selection and Specification.
- Supervision of Installation.
- Commissioning.
- Advice on Maintenance Programmes.
- Rebuilding and Refurbishment.
- Genuine Spare Parts.
- Service Contracts.

Our engineers are highly trained and experienced in the B&W products and familiar with the demands of continuous process industries where plant availability is critical.



Illustrated above the B&W site supervisor demonstrates the proper fitting of the conveyor belt over the Samson™ Apron-Bars.

## THE AUMUND GROUP

### GREAT BRITAIN

**B&W Mechanical Handling Ltd.**  
 Gemini House Cambridgeshire  
 Business Park, 1 Bartholemew's Walk  
 Ely, Cambridgeshire CB7 4EA  
 Phone: +44 - 1353 - 665 001  
 Fax: +44 - 1353 - 666 734  
 e-mail: sales@bwmech.co.uk  
 www.bwmech.co.uk

### GERMANY

**AUMUND Fördererbau GmbH**  
 Saalhofer Str. 17  
 47495 Rheinberg  
 Phone: +49 - 2843 - 72 0  
 Fax: +49 - 2843 - 6 02 70  
 e-mail: aumund@aumund.de  
 www.aumund.com

### AUMUND Fördertechnik GmbH

Saalhofer Str. 17  
 47495 Rheinberg  
 Phone: +49 - 2843 - 72 0  
 Fax: +49 - 2843 - 6 02 70  
 e-mail: aumund@aumund.de  
 www.aumund.com

### SCHADE Lagertechnik GmbH

Dorstener Straße 360  
 44653 Herne  
 Phone: +49 - 2325 - 58 74 0  
 Fax: +49 - 2325 - 58 74 74  
 e-mail:  
 info@schade-lagertechnik.de  
 www.schade-lagertechnik.com

### INDIA

#### AUMUND Engineering Private Ltd.

2nd Floor, Lakshmi Neela Rite Choice  
 Chambers · 9, Bazulla Road,  
 T. Nagar Chennai - 600 017  
 Phone: +91 - 44 - 4393 63 00  
 Fax: +91 - 44 - 2815 60 46  
 e-mail: aumund@vsnl.com

### RUSSIA

#### AUMUND Representative Office Moscow

German-Russian House, Office 44  
 ul. Malaja Pirogovskaja 5  
 119435 Moscow / Russia  
 Phone: +7 495 2879002  
 Fax: +7 495 2879006  
 e-mail: info@aumund.ru

### HONG KONG SAR

#### AUMUND Asia (H.K.) Limited

Suite 1301, Oxford House,  
 Taikoo Place, 979 King's Road,  
 Quarry Bay  
 Hong Kong  
 Phone: +852 - 3695 - 43 33  
 Fax: +852 - 3695 - 43 11  
 e-mail: info@aumund-asia.com

### THE NETHERLANDS

**AUMUND Holding B.V.**  
 Spoorstraat 42-52  
 5911 KJ Venlo  
 Phone: +31 - 77 - 320 01 11  
 Fax: +31 - 77 - 320 07 28  
 e-mail: info@aumund-holding.nl

### SWITZERLAND

#### AUMUND AG

Arther Str. 3  
 6301 Zug  
 Phone: +41 - 41 - 710 10 82  
 Fax: +41 - 41 - 710 42 02  
 e-mail: info@aumund.ch

### POL AND

#### AUMUND Polska Representative Office

ul. Lektorska 34 G · 44-210 Rybnik  
 Phone: +48 - 32 - 426 32 11  
 Fax: +48 - 32 - 426 32 01  
 e-mail: aumund@post.pl

### FRANCE

#### AUMUND France S.A.R.L.

43, rue de Tréville · F 75009 Paris  
 Phone: +33 - 1 - 42 46 72 72  
 Fax: +33 - 1 - 42 46 72 74  
 e-mail: aumund@aumund.fr

### BRAZIL

#### AUMUND Ltda.

Rua Haddock Lobo, 337 - 11. andar  
 01414-001 São Paulo, SP  
 Phone: +55 - 11 - 3059 0160  
 Fax: +55 - 11 - 3059 0161  
 e-mail: aumund@aumund.com.br

### USA

#### AUMUND Corporation

1825 Barrett Lakes Boulevard  
 Barrett Lakes Center II  
 Suite 520  
 Kennesaw, GA 30144  
 Phone: +1 - 770 - 226 - 95 78  
 Fax: +1 - 770 - 953 - 48 44  
 e-mail: sales@aumundusa.com

### P.R. CHINA

#### AUMUND Machinery Trading (Beijing) Co. Ltd.

Rm. 7-8, 22-F, East Ocean Centre  
 No. 24 Jianguomenwai Avenue  
 Chaoyang District  
 Beijing 100004  
 Phone: +86 - 10 - 65 15 58 13 / 14  
 Fax: +86 - 10 - 65 15 58 15  
 e-mail: aumund@aumund.cn



AUMUND GROUP Headquarters in Rheinberg, Germany

## B&W

Products offer a unique concept in bulk materials handling with Surface Mounting and Mobility for maximum flexibility in location and economy in installation and operation.

Often opening new opportunities for processes on short term contract options that with conventional fixed plant or traditional underground hoppers and feeders would not be economically viable.

[www.aumund.com](http://www.aumund.com)

**B&W Mechanical Handling Ltd.**

Gemini House, Cambridgeshire Business Park, 1 Bartholomew's Walk, Ely, Cambridgeshire, CB7 4EA, UK.  
Tel: +44 - 1353 - 665001 • Fax: +44 - 1353 - 666734 • e-mail: [sales@bwmech.co.uk](mailto:sales@bwmech.co.uk)