



PDS-100

Programmable Dispensing System

INSTRUCTION MANUAL

SAFETY INSTRUCTIONS



Before using any Fluid Metering, Inc. product read the following safety instructions as well as specific product specifications and operating instructions.



Warning! Fire, electrical shock or explosion may occur if used near combustibles explosive atmosphere, corrosive air, wet environment or submerged in fluid.

- Turn off the electrical power before checking pump for any problems.
- Connect motor, speed controllers, or any other electrical devices based on Fluid Metering Inc. specifications. Any unauthorized work performed on the product by the purchaser or by third parties can impair product functionality and thereby relieve Fluid Metering, Inc. of all warranty claims or liability for any misuse that will cause damage to product and/or injury to the individual.
- Power cables and leads should not be bent, pulled or inserted by excessive force. Otherwise there is a threat of electrical shock or fire.
- Replace any inline fuses only with fuse rating as specified by Fluid Metering, Inc.
- When pump/drive is under operation, never point discharge tubing into face or touch any rotating components of pump. In a power down thermal overload cut-in condition, unplug or turn off power to pump. Always allow a cool down period before restarting; otherwise, injury or damage may occur.
- For 30 seconds after power is removed from pump/drive: do not touch any output terminals. Electrical shock may occur because of residual voltage.



Caution! Fire, electrical shock, injury and damage may occur if not used in accordance with Fluid Metering, Inc. specifications and operation instructions.

- Do not put wet fingers into power outlet of unit.
- Do not operate with wet hands.
- Do not operate drive assemblies that require a hard mount (to be bolted down) unless they are mounted per Fluid Metering, Inc. specifications, if not injury may occur and/or damage to unit.
- Do not touch any rotating pump or motor components: injury may occur.
- Do not run pump dry, unless designed for that service. Running dry is harmful to the pump, and will cause excessive heating due to internal friction.
- Check pump rotation and inlet/outlet pump port orientation before connecting power to pump. If not injury may occur.
- When pulling out cords from outlets do not pull cord, grasp plug to prevent plug damage or electrical shock.
- Fluid Metering, Inc. Drive Motors become HOT and can cause a burn. **DO NOT TOUCH!**

OVERVIEW

The PDS-100 is a precision system capable of dispensing or pumping fluids ranging from 2.5 μ L per dispense or 8 μ L/min continuous (Single RH00LF) up to 1536 mL/min (Dual Q3) into pressures ranging from 10 psi (Q3) to 100 psi (RH). The PDS-100 offers single, dual (in phase, out of phase and independent) pump head control. PDS-100 offers RS485 communications, which allows the user to control the PDS-100 via a PC or PLC. Dry contact inputs offer an easy method to start and stop the pumps through the use of a simple switch. The PDS-100 also offers inputs which provide control of the dispense rate via a 0 – 10 VDC, 0 – 5 VDC or 4–20 mA input.

A simple easy to use local keypad provides the user access to local control of the pump or pumps and a vivid display to provide user-friendly menus for ease of control.



FEATURES:

- “Set and Forget” approach
- 1-9999 dispenses (adjustable)
- Table top/wall mount
- Universal power supply with standard IEC line cord
- CSA/UL, CE, RoHS compliant
- Learn mode/count to allow customer to command the PDS-100 to “remember” desired dispense cycles needed to fill to a desired volume.
- Prime Mode
- Purge/Reverse Mode

Table-top Mounting: The system is configured for table top installation initially with rubber grommets slid into the mounting slots. Before moving on to configuring the control module, make sure that these rubber grommets are in place. There are no further installation steps for table top use.

Wall-Mounting: For wall mounting, it is necessary to remove the four rubber grommets from the control module before attempting to mount. Each unit must be mounted in the correct orientation; with the labels facing right side up, the control module will have the pumps at the bottom. Wall mounting may require an appropriate mounting board of at least 1/2”(12mm) thickness to straddle the studs of a typical plasterboard wall. See Figure 3.

IMPORTANT When mounting PDS-100 in an enclosure it is important to maintain a minimum clearance to provide adequate space to reach the power switch. See figure 2.

Specifications

Supply Voltage: 100-240VAC +/- 10%, 50/60 Hz. Main Supply Current: 0.6 to 0.25 Amps. Fuses: T250V-1A (time lag), 5x20mm, 2 required.

Physical: Dimensions: 5" H x 6 1/4" W x 12" (max) D; Weight: 7 lbs

Environment: For indoor use only. Humidity: 80% max for temperatures up to 31°C, decreasing linearly to 50% relative humidity at 40°C. Pollution degree, 2. Operating temperatures range from 5°C to 40°C (41°F to 104°F).

Smooth Flow Operation

The PDS Smooth Flow product differs from the “Standard” PDS-100 in that the dual pumps have each been precisely calibrated to provide equal dispenses per revolution. The distinct difference found in the PDS Smooth Flow is in the method by which the pumps are driven. Proprietary programming provides a unique method of control in such a way as to provide a virtually pulseless output when both pumps are connected to a “Y” or “Tee” fitting.

Most of the controls and screens are the same for the Smooth Flow as shown in the previous pages with the exception that the pumps are not individually controllable. Instead the pumps are controlled as though they are one.

Menus, for the most part, are the same except while in dispense or continuous mode the word “Smooth” will appear at the top of the main screen. In addition you will see the word “Smooth Drive” when power is first applied to the unit.

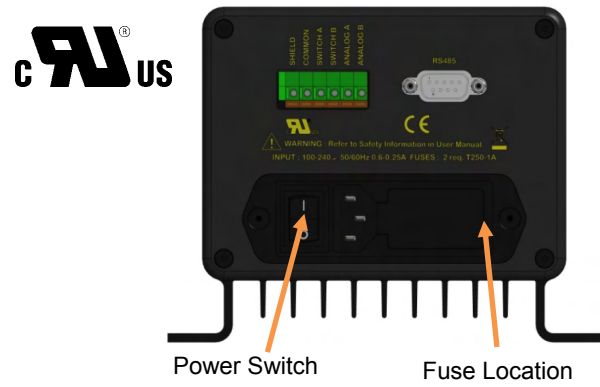

Figure 1
PDS-100 Rear View

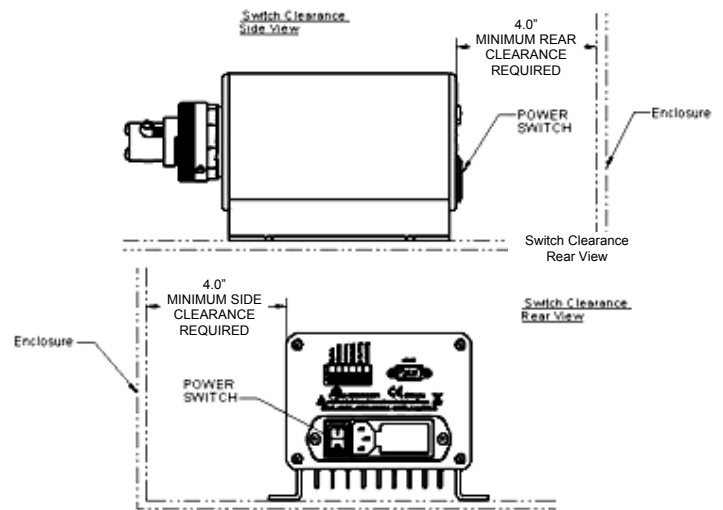

Figure 2
Minimum Power Switch Clearance

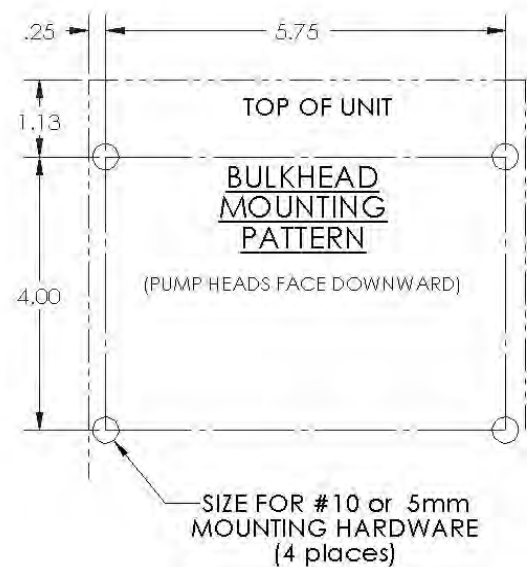

Figure 3
Required Mounting Pattern

Power Up Screens (two individually controlled pumps)

This is what will be seen on power up when the unit is configured for individually controlled pumps (factory default). For Single pump configured system use "Pump A" screens only.

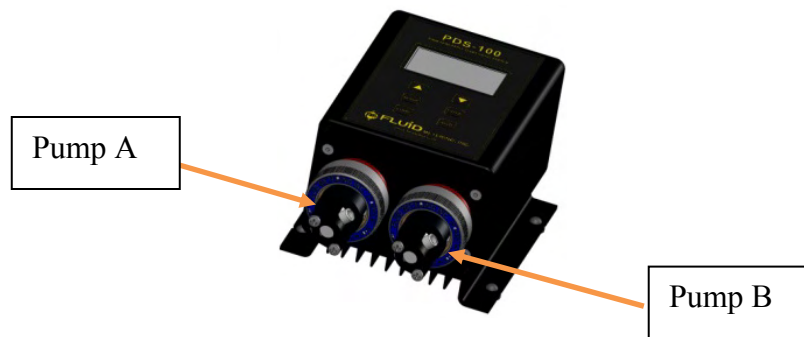
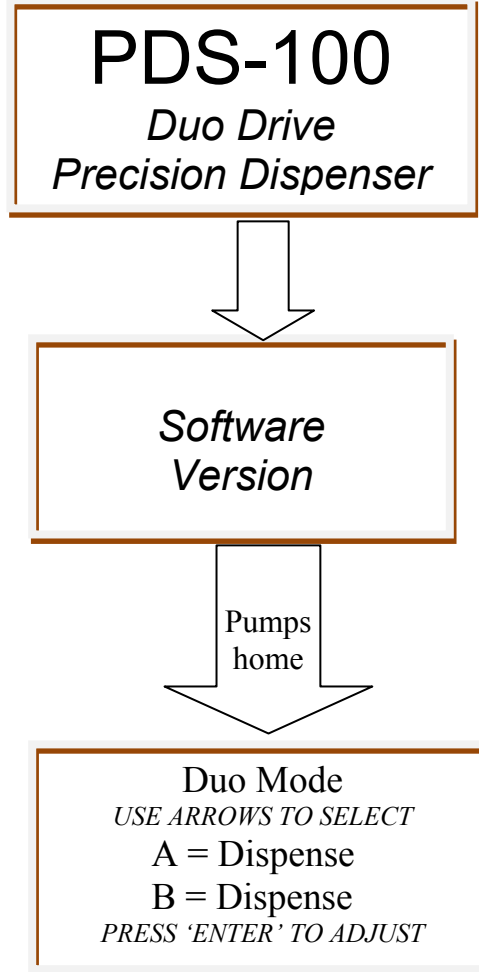



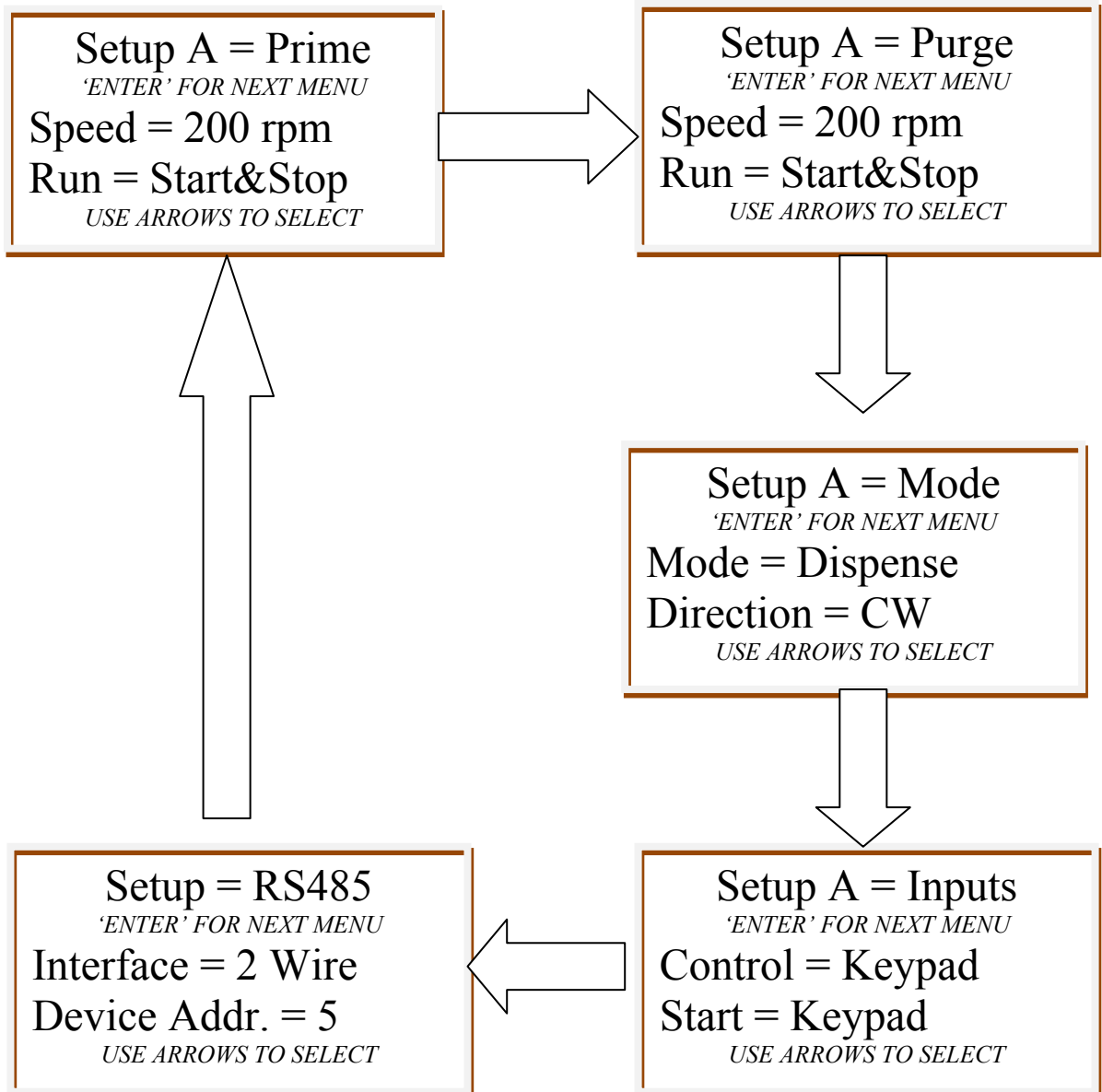

Figure 4
Pump A & Pump B Location

Setup Screens (two individually controlled pumps) Prime/Purge, Mode & Input Setup Screens

To select "Prime/Purge, Mode & Input Setup" screen wait for the pumps to home then press the up/down arrow to select desired pump (A or B: see figure 4) and then press the Setup  button. The following screens are available. Pressing enter  will go to each screen. Pressing the up  or down  arrow will select additional items.

Factory default values shown



Only appears if RS485 is selected for Control mode and/or Start mode on previous (Inputs) screen.











Setup Screens (two individually controlled pumps) cont'd:
Prime/Purge adjust and activation

Prime and Purge have the following available settings.

Setup A = Prime
'ENTER' FOR NEXT MENU
Speed = 200 rpm
Run = Start&Stop
USE ARROWS TO SELECT

Setup A = Purge
'ENTER' FOR NEXT MENU
Speed = 200 rpm
Run = Start&Stop
USE ARROWS TO SELECT

Factory default values shown

- **Speed** (7 – 749 RPM for the STH & RH and 7 – 599 RPM for the STQ & STQP)
- **Run**
 1. Run = “Start&Stop”. Start prime/purge via keypad “Run” and stop prime/purge via “Stop”
 2. Run = “Ext. Switch”. Start prime/purge via external switch. Pump will continue to prime/purge until switch is released. Switch A activates pump A and Switch B activates pump B.
 3. Run – “Start&Hold”. Start prime/purge via keypad “Run”. Prime/purge will continue until the Run button is released.
- To adjust either the speed or run method simply press the up  or down  arrow keys to go to the desired item and then press the enter  key to select. To set the speed press the up/down arrow keys   until the desired speed is shown. Press enter  key to save. To set the desired run method press the up/down   arrow keys until the desired run method is shown. Press enter  key to save. To start the Prime/Purge process use the device chosen (Keypad run button or external switch). To exit setup press the setup  key and the motor(s) will automatically home or press the enter  key to go to the next setup screen.

Setup Screens (two individually controlled pumps) cont'd: Mode and direction adjust





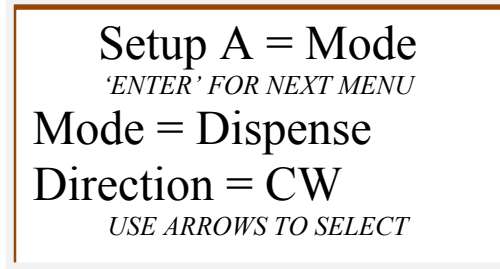





Mode has the following available settings for direction.

Factory default values shown



- **Mode**
 - Continuous (pump will run until a Stop command is given).
 - Dispense (pump will run until a Stop command is given or the programmed dispenses is reached)
- **Direction**
 - CW
 - CCW









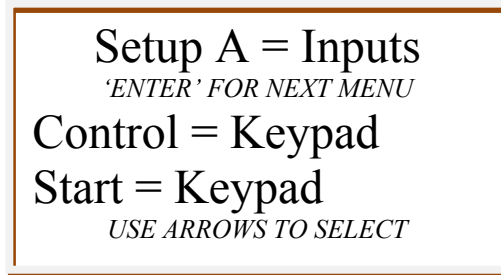





NOTE: When operating in dual pump mode, the direction will change both pumps. Independent direction control is not available.

- To adjust either the mode or direction simply press the up  or down  arrow keys to go to the desired item and then press the enter  key to select. To set the mode press the up/down   arrow keys until the desired mode is shown. Press the enter  key to save. To set the desired direction press the up/down   arrow keys until the desired direction is shown. Press the enter  key to save. To exit setup press the setup  key and the motor(s) will automatically home or press the enter  key to go to the next setup screen.

Setup Screens (two individually controlled pumps) cont'd: Control and start method

Input has the following available settings for Input control type and start method.
Factory default values shown



- **Control** (Speed). Speed can be adjusted prior to run command from one of the following 5 options listed below:
 - **RS485**
 - **4-20 mA**
 - **0-10 V. (VDC)**
 - **0-5 V. (VDC)**
 - **Keypad.** The pump speed can be adjusted via the keypad up/down arrow keys.
- **Start.** The pumps can be activated (started) from one of the following 5 options listed below:
 - **RS485**
 - **Analog** (pump(s) will start when a voltage is applied to the pump(s) Analog Input(s) based on Table 2, pg. 12.
 - **Power Up:** The pumps will start to dispense/meter after power is applied. Note: The pumps initially “home” prior to starting the dispense/metering process. In dispense mode the pumps will stop rotating once the desired dispense count is reached. The keypad stop button can also activate a stop command.
 - **Switch.** Momentary closure will activate a pump in dispense mode. In continuous mode the pumps will only rotate while the switch is closed. Upon switch removal the pumps will complete rotating until “home” is reached.
 - **Keypad.** The pump will start when the keypad start  key is pressed and stop when the stop  key is pressed.
- To adjust either the control method or start method simply press the up  or down  arrow  keys to go to the desired item and then press the enter  key. To set the control method press the up/down   arrow keys until the desired control method is shown. Press the enter  key to save. To set the start method press the up/down   arrow keys until the desired start method is shown. Press the enter  key to save. To exit setup press the setup  key and the motor(s) will automatically home or press the enter  key to go to next setup screen.











Setup Screens (two individually controlled pumps) cont'd

RS485 setup

RS485 has the following available settings for Interface & Device Address



Factory default values shown

Setup = RS485
'ENTER' FOR NEXT MENU
Interface = 2 Wire
Device Addr. = 5
USE ARROWS TO SELECT

- **Interface.** 2 wire or 4 wire
 - **Device Address.** Up to 31 (address #1 to #31) units can be independently addressed.
- To adjust either the interface type or device address simply press the up  or down  arrow keys to go to the desired item and then press the enter  key. To set the interface type press the up/down   arrow keys until the desired control method is shown. Press the enter  key to save. To set the Device Address press the up/down   arrow keys until the desired address is shown. Press the enter  key to save. The address selected applies to both pumps in a dual pump system. To exit setup press the setup  key and the motor(s) will automatically home or press the enter  key to go to the next setup screen.

Main Screen (both pumps in dispense mode): Speed/Strokes adjust via keypad











Duo Mode
USE ARROWS TO SELECT
A = Dispense
B = Dispense
PRESS 'ENTER' TO ADJUST

Press the up/down   arrow keys then the enter  key to adjust the desired pump

A=Dispense
USE ENTER WHEN FINISHED
Speed = 200 rpm
Strokes = 10
USE ARROWS TO ADJUST

Speed can be adjusted based on the control type selected from the Input Setup section in the manual. By default the PDS-100 is configured for Keypad Control and Keypad Start.

A=Dispense
USE ENTER WHEN FINISHED
Speed = 200 rpm
Strokes = 10
USE ARROWS TO ADJUST

To adjust the speed press the up arrow  key and then press the enter  key. Press the up/down   arrow keys to adjust and then press the enter  key when finished to save. To adjust the number of strokes press the down  arrow and then press the enter  key. Press the up/down   arrow keys to adjust and then press the enter  key when finished to save. Press the enter  key one final time to go back to the main screen.

Duo Mode
USE ARROWS TO SELECT
A = Dispense
B = Dispense
PRESS 'ENTER' TO ADJUST

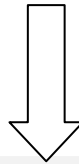

Main Screen (Pump A in continuous mode & Pump B in Dispense mode): Speed adjust from external source

Duo Mode
USE ARROWS TO SELECT
A = Continuous
B = Dispense
PRESS 'ENTER' TO ADJUST



Press the up/down   arrow keys
then press the enter  key to adjust the
desired pump

A = Continuous
USE ENTER WHEN FINISHED
Speed = 200 rpm
Control = Keypad
USE ARROWS TO ADJUST

To adjust the speed press the up/down   arrow keys until the desired speed is set. Notice how the speed immediately begins to adjust. To save press the enter  key. The unit returns to main screen

Duo Mode
USE ARROWS TO SELECT
A = Continuous
B = Dispense
PRESS 'ENTER' TO ADJUST

If the unit has been configured for other forms of speed control other than Keypad then the speed can only be set by that type of control. For example, if the speed control is set for 0-5 V then the following screen will be seen.

A = Continuous
WAITING FOR START KEY
Analog = 200 rpm
Control = 0-5 v.

Analog Input Connector and Specifications

The PDS-100 incorporates a simple screwless (spring loaded) terminal strip (see figure 6) for easy wire (22 to 14 AWG) connection to an external control source such as a PLC. It is recommended that a DIN wire ferrule be used (See figure 5).

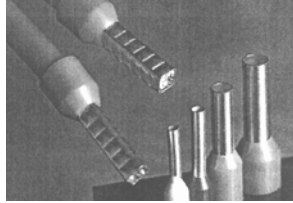

Figure 5
Wire Ferrule

Analog/Switch Input Terminal Strip

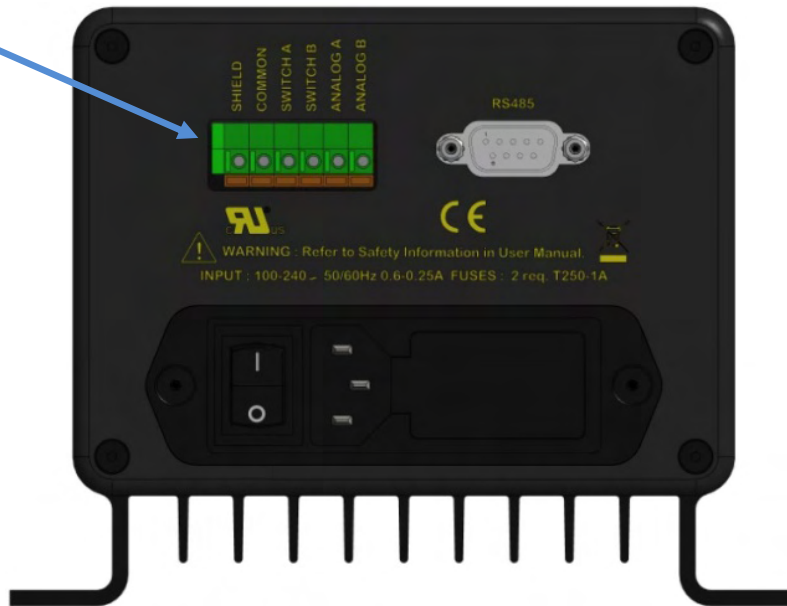

Figure 6
Analog Pump Control Connector (Rear Panel)

Signal	Description
Shield	Cable shield (terminate one end only)
Common	Ground
Switch A	Activates Prime, Purge and Start for Pump A when connected to Common and configured as such
Switch B	Activates Prime, Purge and Start for Pump B when connected to Common and configured as such
Analog A	Controls the speed of Pump A via an external voltage or current when configured as such
Analog B	Controls the speed of Pump B via an external voltage or current when configured as such

Table 1
Analog/Switch Input Connector

Analog Input Connector and Specifications (cont'd)

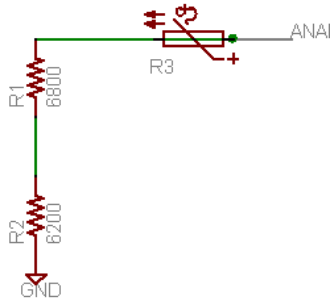

Figure 7
Input Resistance Schematic (Analog input: 0 – 5 VDC or 0 – 10 VDC)

	RPM		4 - 20 (mA) Input resistance 490 ohms (note 3,1)		0.25 - 5 (VDC) (note 2,1)		0.5 - 10 (VDC) (note 2,1)		mA/RPM	Volts/RPM	
	Min	Max	Min	Max	Min	Max	Min	Max	4 - 20 mA	0.25 - 5 VDC	0.5 - 10 VDC
Standard H Pump	6	750	4	20	0.25	5	0.5	10	0.0215	0.0064	0.0128
Standard Q Pump		600									

Table 2
Input Voltage/Current versus RPM

Note 1: Maximum current is reduced provided control method is set according to actual input method (ie 0 – 5 VDC or 0 – 10 VDC). If desired control method is set for “4–20mA” but a 0 – 5 VDC or 0 – 10 VDC is applied the maximum current will be at its greatest.

Note 2: Absolute maximum input voltage is 10.8 VDC

Note 3: Absolute maximum current is 22 mA

When start/stop is controlled via the analog input the pump(s) will stop when the analog input goes below the minimum voltage/current. The pumps will run when the minimum voltage/current is reached and will run at the minimum speed.

RS485 Connector Pin, command set and specifications

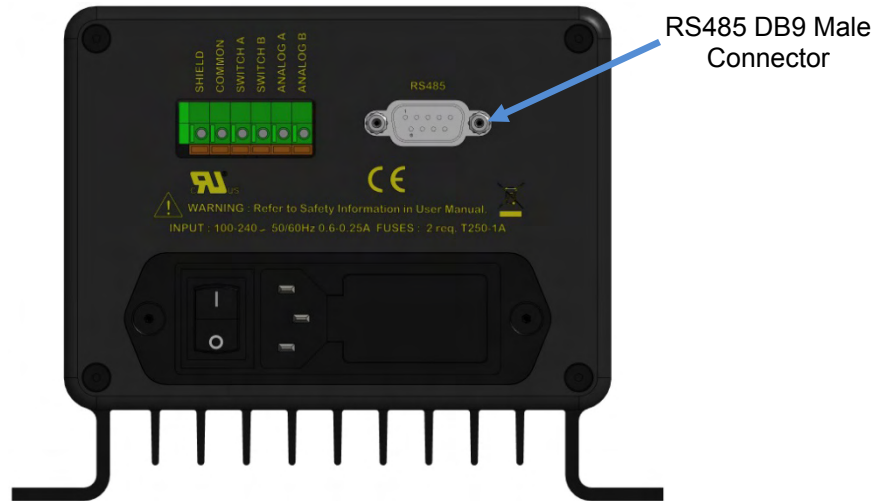

Figure 8
RS485 Control (Rear Panel)

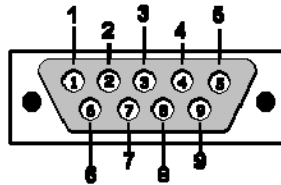

Figure 9
RS485 Control (Rear Panel)

Pin On DB9 Male Connector	Signal	EIA/TIA-485 name
8	RXD0	A'
4	RXD1	B'
5	TXD1	B
9	TXD0	A
1	Common	C/C'

Table 3
RS485 DB9 pin out assignments

PDS-100 follows the guidelines per **MODBUS over Serial Line protocol**

Port Settings

Baud Rate 19,200
 Stop Bits 1
 Data Bits 8
 Parity Even

RS485 Connector Pin, command set and specifications (cont'd)

Note: PDS-100 accommodates up to 31 addressable units.

Command Mapping

Single bit read and write. Set bit to initiate action, PDS-100 will clear bit upon execution

Coil 0 = "start"

Coil 1 = "stop"

Coil 2 = "start-2"

Coil 3 = "stop-2"

Single bit status, read only

Input 0 = "busy"

Input 1 = "error"

Input 2 = "busy-2"

Input 3 = "error-2"

16 bit word read and write. Not allowed to change when pump is busy

Holding Register 0 = "rpm"

Holding Register 1 = "stroke count"

Holding Register 2 = "rpm-2"

Holding Register 3 = "stroke count-2"

16 bit word information read only

Input Register 0 = "configuration"

Input Register 1 = "operating mode"

Input Register 2 = "operating mode-2"

Input Register 3 = "error code"

Input Register 4 = "error code-2"

Input Register 5 = "minimum-speed"

Input Register 6 = "maximum-speed"

Configuration Modes Screens



(Appears when Up  Arrow and setup  Keys are held down while powering up unit)

The unit comes pre-configured as a Dual Individual system when purchased as a dual pump system. To configure the dual pump system for “In Phase” operation or “Out Phase” operation follow the procedure mentioned above to modify. If the unit supplied is a single pump system there is no need to change the configuration.

Possible drive configurations types supported (configured by factory):

1. **Single:** Single pump.
- * 2. **Individual:** Two pumps that can be controlled independently
3. **In Phase:** Two pumps that are in phase with each other.
4. **Out of Phase:** Two pumps that run 180 degrees out of phase for each other.
5. **Smooth:** Requires factory calibrated pump drive assembly. Not covered in this manual.

*** Default Setting**

The following screens will be seen when entering the configuration mode. The configuration mode can only be entered if the up  arrow key and setup  keys are held down while powering on the unit.

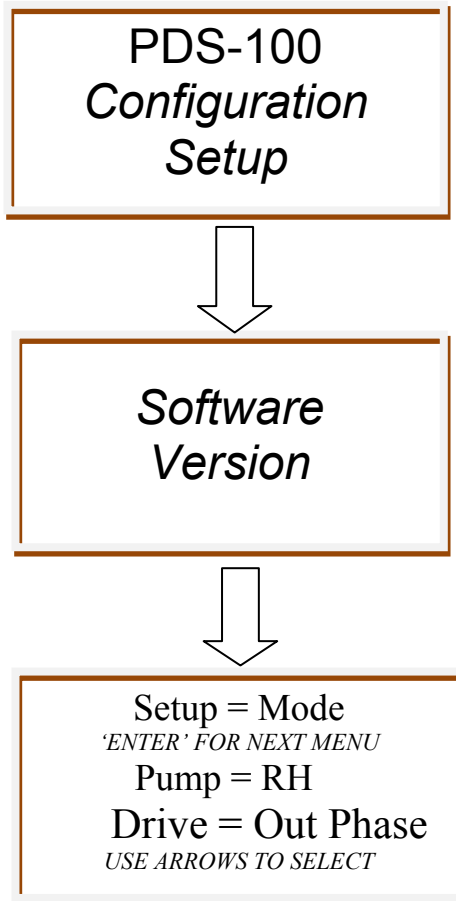



FLUID METERING, INC.
 5 AERIAL WAY, SUITE 500, SYOSSET, NY 11791
 (800) 223-3388 (516) 922-6050 Fax: (516) 624-8261 <http://www.fmipump.com>

EC DECLARATION OF CONFORMITY

Product Name: FMI Programmable Dispensing System 100-240VAC +/- 10%, 50/60 Hz

Model Numbers: PDS-100

Description: PDS-100 (Programmable Dispensing System) can be used with FMI's full range of Q and H pump heads either as a dual pump system or single pump system. The system allows for control of a pump via a local keypad or remotely via external peripheral such as a computer or PLC.

Specifications for which conformity is declared	File Number	Certified Laboratories Report/Certificate Number
EN61326-1 (2006) EN61000-3-2 (1995) EN61000-3-3 (2006)	E203837	940472
IEC 61010-1:2001, 2nd Edition (CB Scheme)	E203837-A1-CB-1	US/12909/UL

Year in which the current configuration of the above models was accessed: 2008

Manufacturer:

Fluid Metering, Inc.
 5 Aerial Way, Suite 500
 Syosset, N.Y. 11791

Manufacturer's Signature:

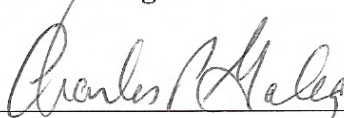

 Charles Galea
 Quality Assurance Manager

1/12/09

 Date

Pump	Size	Speed (RPM)				Min Displacement (5% of max stroke) (mL/rev)	Max Displacement (mL/rev)	Dispense Rate (mL/min) (Minimum Displacement)		Dispense Rate mL/min (Maximum Stroke)						Pressure max (psi)		
										Single		Dual				Single	Dual	
		Standard		Smooth				Per Pump (Non-Smooth)	Smooth	2 Independent "Solo" pumps		Smooth flow		2 Independent "Solo" pumps each	Smooth flow			
		Min	Max	Min	Max					Min (@ Minimum Speed)	Max (@ Maximum Speed)	Min (@ Minimum Speed)	Max (@ Maximum Speed)			Min (@ Minimum Speed)	Max (@ Maximum Speed)	
RH	00 (1/8)	6	750	6	200	0.00125	0.025	0.0075	0.015	0.15	18.75	0.30	37.5	0.300	10	100	60	
	0 (3/16)					0.0025	0.050	0.0150	0.030	0.30	37.50	0.60	75.0	0.600	20			
Q	0 (1/8)	6	750	6	200	0.004	0.080	0.0240	0.048	0.48	48.00	0.9600	96.0	0.960	32	40	20	
RH	1 (1/4)					0.005	0.100	0.0300	0.060	0.60	75.00	1.20	150.0	1.2	40	100	60	
Q	1 (1/4)	600	750	6	200	0.016	0.320	0.0960	0.192	1.92	192.00	3.84	384.0	3.840	128	40	20	
	2 (3/8)					0.036	0.720	0.2160	0.432	4.32	432.00	8.64	864.0	8.640	288	20		
	3 (1/2)					0.064	1.280	0.3840	0.768	7.68	768.00	15.36	1536.0	15.360	512	10		

Table 4
Pump Operating Parameters