

**Model 84F (Style B) Flanged Body Flowmeters
with HART Communication Protocol**



The Foxboro® brand I/A Series® Model 84F Style B flanged vortex flowmeter is part of a family of intelligent, high performance vortex flowmeters⁽¹⁾. It transmits a 4 to 20 mA or digital multidrop, and a pulse output signal, as applicable, using HART communication protocol for remote configuration, calibration, and monitoring. An on-board LCD indicator with pushbuttons is also offered for local configuration.

FEATURES

- ▶ Liquid, gas, or steam applications.
- ▶ Best in class accuracy:
 - $\pm 0.5\%$ of reading in liquids.
 - $\pm 1.0\%$ of reading in gas and steam.
- ▶ Flanged body designs:
 - 3/4 to 12 in (DN15 to DN300) flanged body.
- ▶ High pressure options up to Class 1500 and PN160.
- ▶ **DirectSense**™ technology with lifetime sensor warranty.
- ▶ Widest rangeability in class.
- ▶ Active Tuning™:
 - Real time Reynolds number (R_D) low flow correction down to R_D of 5000.
 - Compensation for piping effects.
 - Adaptive filtering and signal conditioning.
- ▶ HART communication protocol, 4 to 20 mA, and pulse outputs.
- ▶ Pulse output provides raw or scaled frequency, or total.
- ▶ Low power versions available for use in battery or solar power applications.
- ▶ CE marked; complies with EMC European Union and PED Directives, and NAMUR NE 21 interference immunity requirement.
- ▶ A free-to-use, flow sizing tool is available on the internet at www.FlowExpertPro.com. See next page.

(1) For information on other flowmeters in the Model 84 family, refer to PSS 1-8A3 A (Style A Models 84F and 84W), PSS 1-8A5 A (Style A Model 84S), and PSS 1-8A6 A (Low Power Style A Models 84F, 84W, and 84S).

WIDE VARIETY OF APPLICATIONS

The Foxboro Model 84F (Style B) sets the example for industry standards whether the application requires accuracy for totalizing and batching; utility metering of fluids in the process industries; fuel, air, steam, or gas metering for the measurement of energy in any high use application; or stability and repeatability for process control.

The Low Power versions of the Vortex Flowmeters differ from other 84 Series Vortex flowmeters in that the supply current is fixed at a constant 10 mA, and remain in operation down to a minimum voltage of 10V dc. They are intended for use with battery power with any form of recharging technology such as solar arrays or alternators.

COMPLIANCE WITH EUROPEAN UNION DIRECTIVES

- ▶ Complies with Electromagnetic Compatibility Requirements of EMC Directive 2004/108/EC by conforming to the following EN and IEC Standards: EN 61326-1 and IEC 61000-4-2 through 61000-4-6.
- ▶ Complies with NAMUR NE 21 Interference Immunity Requirement (EMC).
- ▶ Complies with Pressure Equipment Directive (PED) 97/23/EC.
- ▶ Complies with all applicable European Union Directives (CE Logo marked on product).

PATENTED *DirectSense*™ TECHNOLOGY ENSURES BEST PERFORMANCE AND RELIABILITY

This patented family of vortex flowmeters has the high accuracy and rangeability of positive displacement and turbine flowmeters without the mechanical complexity and high cost. They provide flow rate accuracy of $\pm 0.5\%$ in liquids and $\pm 1.0\%$ in gas and steam. It utilizes patented *DirectSense* technology to eliminate routine problems encountered with other vortex meters.

DirectSense technology measures pressure pulses from vortex shedding directly, without losses due to mechanical linkages. The benefits of *DirectSense* technology include:

- ▶ Provides best-in-class performance.
- ▶ Increased measurement sensitivity for wider rangeability.
- ▶ Greater immunity to pipe vibration.
- ▶ High reliability backed by lifetime sensor warranty.
- ▶ Replaceable sensor without recalibrating.

Because these vortex flowmeters have no moving parts, they are very durable and reliable. The simplicity of design ensures low initial cost, low operating and maintenance costs, which contribute to an overall lower cost of ownership.

SIMPLIFIED START-UP

No primary device calculations or mechanical calibrations are required. The flowmeter is easily installed and configured. Simply wire it to a proper power source, an I/O module, or controller, and it is ready to measure flow.

Invensys will preconfigure the flowmeter using flow data supplied by the customer. Generically preconfigured flowmeters can be used as shipped, but for more precise application, the flowmeter should be configured to specific process usage. The configurator allows selection of the fluid type, and provides general default configurations when process conditions are not available.

ActiveTuning™

Reynolds Number

Patented algorithm improves accuracy performance down to an R_D of 5000.

Compensations for Piping Effects

When it is not possible to provide the recommended pipe diameters of unobstructed straight pipe upstream of the flowmeter, the 84 Series can be configured to compensate for most of the common non-ideal upstream conditions, such as elbows and reducers. Straight runs as short as 5-pipe diameters can be configured to achieve full accuracy.

Adaptive Filtering and Signal Conditioning

A patented, adaptive filtering algorithm provides real-time, dynamic frequency filters that follow the vortex shedding frequency. This results in unsurpassed low-flow measurement capability and vibration immunity. This is incorporated with a digital smoothing algorithm that conditions the raw vortex signal to virtually eliminate dropped or added pulses, further enhancing low-flow performance.

Tunable for Specific Operating Conditions

Configurable parameters for Low Flow Cut-in and damping allow tuning for specific flow conditions.

COMPACT, EFFICIENT, AND DURABLE DESIGN

The flowmeter mounts between ANSI or DIN EN 1092-1 raised face flanges. See Model Code section for end connections offered with each line size. Other flange face surfaces can be used as a custom design.

The electronics housing is of explosionproof and flameproof construction and provides environmental protection to the enclosed electronics. It is offered integrally mounted to the flowtube, or can be mounted remotely.

The flowmeter's simple, modular design requires minimum maintenance. Common, field replaceable parts are used, including the sensor assembly and amplifier. The amplifier can be replaced without interrupting the flow in the pipe, and sensor can be replaced without process shutdown when an isolation valve is installed. Since a single device is used for multiprocess-fluid applications, ordering is simplified and spare part needs minimized.

USABLE IN HAZARDOUS AREA LOCATIONS

Meet numerous Agency requirements for hazardous locations. Versions available to meet Agency flameproof and zone requirements.

MEASUREMENT INTEGRATION

These flowmeters provide efficient integration of measurements into HART process control schemes, as follows.

HART -T and -U Versions

These versions operate by using a bidirectional digital signal superimposed on the 4 to 20 mA current signal. They are also offered with or without a pulse output. Remote communication of digital values plus status and configuration information can be achieved via HART communication protocol.

Configurators used with the HART versions are:

- ▶ The HART Communicator (users having a HART Communicator for other devices can have them upgraded with Invensys Foxboro software to accommodate these flowmeters).
- ▶ The Local Digital Indicator/Configurator with pushbuttons.

With HART, digital multidropping is permitted. This is the connection of several transmitters to a single communications line. Up to fifteen transmitters can be connected on a single twisted pair of wires or over leased telephone lines.

REMOTE MOUNTED ELECTRONICS HOUSING

Remote mounting is offered to allow access to the amplifier and other housing electronics when the measurement is not in an easily accessible location. The remote housing is supported by a bracket, which in turn mounts to a surface or to a nominal 2-in or DN50 pipe. This housing can be located up to a cable length of 50 ft (15.2 m) from the flowtube without loss of low level signal.

LOCAL DIGITAL INDICATOR/CONFIGURATOR

This is a full feature, 16-character digital indicator and configurator. Total flow and/or the instantaneous flow rate may be displayed in user-selected flow units. The display may be configured for either flow or total, or to toggle between them. Four pushbuttons on the indicator are used to configure the flowmeter.

ISOLATION VALVE

An isolation valve allows the sensor to be removed or replaced without interrupting the flow in the pipe.

FlowExpertPro™

FlowExpertPro is a tool primarily used to size Foxboro flowmeters. It also ensures that the user has selected the proper flowmeter type for this application. This meter selection tool is provided to all users on a free web site, without the need for registration. In addition to flowmeter selection and sizing, FlowExpertPro includes the following features:

- ▶ Incorporates a large library of the physical properties of typical process fluids.
- ▶ Displays results in tabular or graphic format.
- ▶ Allows user to save, print, or E-mail results.
- ▶ Provides reference to applicable flowmeter PSSs and other related flowmeter documentation.

The program calculates minimum and maximum flow rates, rangeability, pressure loss, and Reynolds Number, using established flow equations. It also allows for material and flange selection, and provides ANSI or DIN flange recommendations for predicted flow pressure and temperature. You are invited to visit www.FlowExpertPro.com to access this tool, or contact Invensys for further information and technical support.

DUAL MEASUREMENT FLOWMETER

Dual measurement flowmeters provide the user with redundant sensors and electronics. Two electronics housings and sensors are mounted to a common flowmeter body assembly. Should one transmitter fail, the redundant measurement avoids the necessity of shutting down the process. The failed transmitter can then be replaced at some later noncritical time. Applications include Safety Shutdown Systems (independent of Process Measurement Network), Safety Backup for critical flow loops, Comparative Verification of Measurement for high accuracy precision loops, or just for dual communications paths with the same primary element. See Figure 1.



Figure 1. Dual Measurement Flowmeter

OPERATING CONDITIONS^(a)

Influence	Factory Calibration Conditions ^(b)	Operating Limits
Process Fluid	Clear Water	Liquid, Gas, and Steam
Process Temperature <ul style="list-style-type: none"> ▶ Std. Temp. Version/Fluorolube Fill ▶ Std. Temp. Version/Silicone Fill ▶ High Temp. Version/Unfilled^(d) 	<ul style="list-style-type: none"> ▶ 70° to 85°F (20° to 30°C) ▶ 70° to 85°F (20° to 30°C) ▶ 70° to 85°F (20° to 30°C) 	<ul style="list-style-type: none"> ▶ 0° and +200°F (-20° and +90°C) ▶ 0° and +400°F (-20° and +200°C) ▶ 400° and 800°F (200° and 430°C)
Ambient Temperature (Housing) <ul style="list-style-type: none"> ▶ with Indicator/Configurator ▶ without Indicator/Configurator 	<ul style="list-style-type: none"> ▶ 70° to 85°F (20° to 30°C) ▶ 70° to 85°F (20° to 30°C) 	<ul style="list-style-type: none"> ▶ 0° and +176°F (-20° and +80°C)^(c) ▶ -40° and +176°F (-40° and +80°C)^(c)
Relative Humidity	50 to 90%	0 and 100%
Supply Voltage	24 ± 0.5 V dc	15.5 and 42 V dc (see Figure 3) 10 and 42 V dc for Low Power version ^(e)

(a) Limits are based on nonflashing, noncavitating conditions. A minimum positive back pressure is required for proper operation to avoid these effects.

(b) The factory calibration conditions assume: ANSI Schedule 160 process piping for 2-, 3-, and 4-inch line sizes using Class 1500 flanges, 6-inch (152.4 mm) and 8-inch (203.2 mm) line sizes using Class 900 and Class 1500 flanges, and DN150 and DN200 line sizes using PN160 flanges; all other line sizes and pressure options assume ANSI Schedule 40 process piping; flanges bored to interfacing pipe I.D.; piping and flowmeter body bores aligned to within 2% of meter bore; gaskets to be 0.125 in (3.18 mm) thick and not protruding into pipeline; a minimum of thirty pipe diameters of straight pipe upstream and five pipe diameters downstream of flowmeter; clear water is free from air or particles.

(c) The 176°F (80°C) temperature is extended to 185°F (85°C) with certain electrical approvals or certifications. Refer to Electrical Safety Specifications table further in document.

(d) Model 84F (Style B) requires the E or G option for upper operating limit above 700°F (370°C).

(e) Supply current is fixed at a constant 10 mA and remains in operation down to a minimum terminal voltage of 10 V dc. See Power Supply Requirements (Low Power Version) NOTE in the FUNCTIONAL SPECIFICATIONS section.

**PERFORMANCE SPECIFICATIONS
(UNDER CALIBRATED OPERATING CONDITIONS UNLESS OTHERWISE STATED)**

Factory Calibrated Flow Ranges

Nominal Meter Size	Nominal Mean K-Factor in Pulses/ft ³ (Pulses/L) ^(a)	Factory-Calibrated Flow Range for Water ^(b)		
		Range in US gpm	Range in L/s	Range Reynolds Number (R _D)
3/4 in (DN15)	5580 (197)	6.9 to 34	0.43 to 2.1	30 000 to 150 000
1 in (DN25)	2250 (79.5)	8.9 to 56	0.56 to 3.5	30 000 to 190 000
1 1/2 in (DN40)	570 (20.1)	14 to 140	0.88 to 8.7	30 000 to 300 000
2 in (DN50)	258 (9.11)	18 to 230	1.1 to 15	30 000 to 380 000
2 in (DN50) Class 1500	389 (13.74)	16 to 203	1 to 12.8	30 000 to 380 000
3 in (DN80)	78.7 (2.78)	34 to 500	2.1 to 32	38 000 to 570 000
3 in (DN80) Class 1500	103 (3.64)	32 to 475	2 to 30	38 000 to 570 000
4 in (DN100)	34.8 (1.23)	59 to 890	3.7 to 56	50 000 to 750 000
4 in (DN100) Class 1500	47.29 (1.67)	55 to 818	3.4 to 51.6	50 000 to 750 000
6 in (DN150)	10.00 (0.353)	140 to 2000	8.5 to 130	76 000 to 1 100 000
6 in (DN150) Class 900, Class 1500, PN160	13.68 (0.483)	125 to 1812	7.9 to 114.3	76 000 to 1 100 000
8 in (DN200)	4.26 (0.150)	240 to 3600	15 to 220	100 000 to 1 500 000
8 in (DN200) Class 900, Class 1500, PN160	5.98 (0.211)	216 to 3244	13.6 to 204.6	100 000 to 1 500 000
10 in (DN250)	2.19 (0.0773)	395 to 5768	24.9 to 363.9	130 000 to 1 900 000
12 in (DN300)	1.32 (0.0466)	578 to 8305	36.4 to 524.0	160 000 to 2 300 000

(a) The K-factor is the relationship between input (volumetric flow rate) and the output (pulse rate).

Reference K-factor is the arithmetic mean value of K-factor over a designated flow rate range (reference conditions).

The mean K-factor is derived as:

$$\text{Mean K-factor} = (K_{\text{MAX}} + K_{\text{MIN}}) / 2$$

Where K_{MAX} is the Maximum K-factor and K_{MIN} is the Minimum K-factor over the calibrated flow range.

(b) Factory calibrated Reynolds Number range applies to standard temperature sensor without isolation valve. Other sensor selections and manifold selections may alter the calibration range. For sizing tools and specific calibration ranges, visit

www.FlowExpertPro.com.

PERFORMANCE SPECIFICATIONS (CONT.)

Accuracy for Liquids

Accuracy within the calibrated range is as follows (also see Figure 2):

- ▶ Above 30000 R_D ; $\pm 0.5\%$
- ▶ Between 20000 and 30000 R_D ; $\pm 1.0\%$
- ▶ Between 5000 and 20000 R_D ; $\pm 2.0\%$

Accuracy for Gases and Steam

Accuracy within the calibrated range is as follows:

- ▶ Above 20 000 R_D ; $\pm 1.0\%$
- ▶ Between 5 000 and 20 000 R_D ; $\pm 2.0\%$

NOTE

To achieve the fluid accuracies listed above, the flowing density and viscosity must be entered in the database configuration. To determine accuracy for specific applications and use other sizing tools, visit www.FlowExpertPro.com.

Supply Voltage Effect (Within Stated Limits)

WITH PULSE OUTPUT

No effect on accuracy

WITH ANALOG OUTPUT

Less than 0.005% per volt

WITH DIGITAL OUTPUT

No effect on accuracy

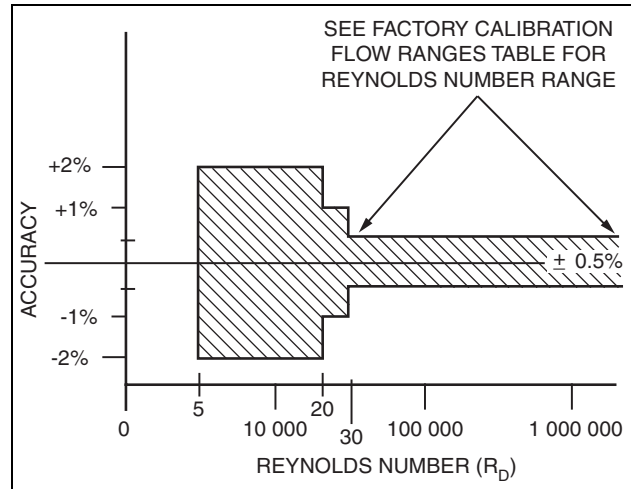

Figure 2. Flowmeter Accuracy for Liquids

Ambient Temperature Effect (Amplifier only)

WITH PULSE OUTPUT

$\pm 0.01\%$ of reading from -40° to $+176^\circ\text{F}$ (-40° to $+80^\circ\text{C}$)(2)

WITH ANALOG OUTPUT

For 50°F (28°C) change in ambient temperature within operative limits.

Zero (4 mA)

$\pm 0.02\%$ of span maximum

Span (16 mA)

$\pm 0.1\%$ of span maximum

WITH DIGITAL OUTPUT

$\pm 0.01\%$ of reading from -40° to $+176^\circ\text{F}$ (-40° to $+80^\circ\text{C}$)(1)

Relative Humidity Effect

No effect if covers and conduit seals are properly installed.

EMI and RFI Effects

The flowmeters meet the EMI and RFI requirements of EN 61326-1.

(2) The 176°F (80°C) temperature may be extended to 185°F (85°C). Refer to Electrical Safety Specifications table further in the document.

PERFORMANCE SPECIFICATIONS (CONT.)

Vibration Effect

Vibration can affect the flow measurement output of a Vortex flowmeter in the form of added pulses, but with the built-in Tuning functions and Low Flow Cut-in adjustability, these effects can be minimized. Invensys has tested this meter with vibrations up to 3 “g” of acceleration with no physical damage, no shift in calibration after the test, and no loss of communications throughout the test.

Position Effect (Filled Pipe Conditions)

For most applications, the flowmeter can be mounted in a pipeline which may run in any direction from the vertical (flow in upward direction) to the horizontal. Measurement of liquid and gas streams is not effected by the pipeline orientation or the flowmeter orientation in the pipeline.

For saturated steam, the recommended flowmeter position is in a horizontal pipe with the electronics housing located below the pipeline.

For superheated steam, the electronics housing may be left or right or below the pipeline. The flowmeter should be insulated to maintain superheat conditions within the flowmeter, as well as insulating the electronics away from the rising heat. The electronics temperature should not exceed 176°F (80°C) under any conditions.

Refer to Recommended Mounting Arrangements section for further information.

Switching and Indirect Lightning Transients

The transmitter can withstand a transient surge up to 2000 V common mode or 1000 V normal mode without permanent damage. Transmitter complies with ANSI/IEEE C62.41-1980 and IEC Std. 61000-4-5.

- ▶ Complies with Electromagnetic Compatibility requirements of European EMC Directive 2004/108/EC by conforming to the following EN and IEC standards: EN 61326-1 and IEC 61000-4-2 through 61000-4-6.

RFI Effect

The output error is less than 0.1% of span for radio frequencies from 27 to 1000 MHz and field intensity of 15 V/m when the transmitter is properly installed with shielded conduit and grounding, and housing covers are in place. (Per IEC Std. 61000-4-3).

FUNCTIONAL SPECIFICATIONS

Remote Digital Communication

Remote digital communication is through a HART Communicator or PC-based Configurator at a communication rate of 1200 baud, and a rated communication distance of 6000 ft (1800 m). Remote digital communication is also through an I/A Series System.

Local Communication/Configuration

In addition to remote communications, a local digital indicator/configurator with pushbuttons is also available for local interrogation and configuration.

Communication Format

- ▶ Analog 4 to 20 mA with HART superimposed
- ▶ HART communications with fixed mA output

Table 1. Remote Communication Parameters

Parameter	HART	
	Analog Mode	Digital Multidrop Mode
Remote Configurator/Communicator	HART Communicator or PC-based Configurator	
Communication Rate	1200 baud	1200 baud
Communication Distance (Rated)	6000 ft (1800 m)	6000 ft (1800 m)
Flow/Total Measurement Update	5 times/s	5 times/s
Raw Pulse Measurement Update	– Vortex Shedding Frequency –	

FUNCTIONAL SPECIFICATIONS (CONT.)

Write Protect Jumper

A write protect jumper provides additional security by allowing the user to prevent the local indicator (configurator) and remote configurator from writing to the electronics. This write protection capability meets the security requirements of ISA-584.01-1986.

Password Protection

This is provided in the local display/configurator mode to assure operating security. A second level of protection is provided for configuration security.

On-Line Diagnostics

Flowmeter uses many internal diagnostic functions including hardware checks, and internal code and database validation. Error checking and diagnostic codes are also embedded in the communications protocol. These diagnostics are performed at startup and as continuous background checks.

Offline Diagnostics (Self-Test)

The configurators allow self-tests to be initiated to validate the transmitter electronics. This test uses an internally generated frequency signal.

Power Supply Requirements

SUPPLY CURRENT

DIGITAL MODE

10 mA dc nominal

ANALOG MODE

22 mA dc maximum

PULSE OUTPUT

20 mA dc maximum

SUPPLY VOLTAGE

15.5 to 42 V dc, depending on electrical safety approvals and certifications. Refer to Figure 3.

NOTE

When operating at ambient temperatures below -20°F (-29°C), it is important to maintain a minimum loop voltage of 15.75 V dc to maintain remote configurator communications capability.

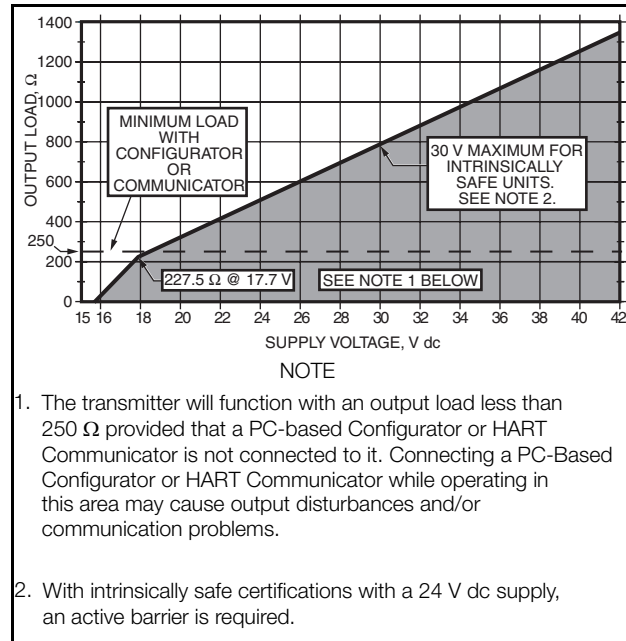

Figure 3. Supply Voltage vs Output Load for 4 to 20 mA Output

Power Supply Requirements (Low Power Version)

SUPPLY CURRENT

10 mA dc nominal

SUPPLY VOLTAGE

SUPPLY VOLTAGE LIMITS

10 and 42 V dc

NOTE

For proper operation, 10 V dc must be maintained at the flowmeter terminals. For HART communications, a 250 Ohms load resistor must be included in the power supply loop and a supply voltage of 12.5 V dc must be maintained. See installation MI for typical installation topologies.

FUNCTIONAL SPECIFICATIONS (CONT.)

Output Damping

Damping smooths the flow rate output, and optimizes the flowmeter's response time to the control system. Damping is an exponential filter, 90% recovery time to an 80% input step, with a selectable time constant; it can be set between 0 and 32 seconds. An eight second damping factor will pass 64% of the step change in this time period. Damping applies to all outputs except the Raw Pulse Output where no damping is applied to the direct vortex shedding frequency.

Response Time (Without Damping)

ANALOG MODE

0.5 second or the vortex shedding period for frequencies less than 2 Hz.

DIGITAL MODE

0.5 second or the vortex shedding period for frequencies less than 2 Hz.

PULSE OUTPUT

- ▶ Raw Pulse: Vortex shedding frequency
- ▶ Rate or Total Pulse: 0.25 s or the vortex shedding period for frequencies less than 2 Hz.

Outputs

These Flowmeters with full-featured electronics can support the following outputs:

- ▶ HART Version -T: Digital and 4 to 20 mA output, with a pulse output
- ▶ HART Version -U: Digital and 4 to 20 mA output

ANALOG OUTPUT

Flow rate available as a 4 to 20 mA signal with the 20 mA value being set by the configured full range flow rate.

DIGITAL OUTPUT

Digital Information is superimposed on a 4 to 20 mA signal at 1200 baud (see Table 1). For low powered versions, output is fixed at 10 mA.

PULSE OUTPUT

The pulse output can be configured with the full-function electronics: raw pulse, rate pulse, and total pulse.

Raw Pulse

This is the vortex shedding frequency directly passed through providing an instantaneous, nondampened frequency output.

Rate Pulse

The frequency of this output is a 50% duty cycle pulse output with a frequency range of 0 to 10, 0 to 100, or 0 to 1000 Hz, proportional to zero flow to the full range flow rate/upper range value (URV).

Total Pulse

The frequency of this output is also a 50% duty cycle pulse output that is configured to provide a pulse when a determined volumetric/totalized unit has flowed through the meter.

Pulse Output Specifications

The pulse output is an externally powered 2-wire transistor switch type output. This output can be configured using any applicable configuration device to select any one of three types of pulse outputs: raw pulse, rate pulse, and scaled pulse. The following specifications apply to all three types of outputs:

- ▶ Isolated 2-Wire Transistor Switch
- ▶ Applied Voltage: 5 to 30 V dc
- ▶ Maximum "ON" State Voltage Drop: 1.0 V dc
- ▶ Maximum "ON" State Current: 20 mA
- ▶ Reverse polarity protected
- ▶ Short circuit protected
- ▶ Connectable to pull up or pull down counters.

Output Combinations (4 to 20 mA Outputs)

Flowmeter wired as a 2-wire device without pulse output, and as a 4-wire device with pulse output.

FUNCTIONAL SPECIFICATIONS (CONT.)

Flowmeter Ranges

Flowmeter is shipped with flow range specified in the sales order or with a default flow range equal to the meter capacity. It can be reranged by the user keeping the same flow rate units, choosing new flowrate units from a built-in menu-selectable list, or entering custom flow rate units. Table 2 is included for reference only. To determine flow velocity limits and use other sizing tools, visit www.FlowExpertPro.com.

Nominal Flow Velocity Limits

These limits can be calculated using Table 2. In the table, ρ_f is the fluid density at flowing conditions in lb/ft³ for U.S. customary units, or in kg/m³ for SI units. The specifications apply for most applications, but can deviate slightly for some combinations of density and line size.

Table 2. Nominal Flow Velocity Limits

Range Limit	Standard Temperature Range		Extended Temperature Range	
	ft/s	m/s	ft/s	m/s
Lower ^(a)	$2.5/\sqrt{\rho_f}$	$3.0/\sqrt{\rho_f}$	$5.0/\sqrt{\rho_f}$	$6.0/\sqrt{\rho_f}$
Upper	$250/\sqrt{\rho_f}$	$300/\sqrt{\rho_f}$	$250/\sqrt{\rho_f}$	$300/\sqrt{\rho_f}$

(a) Values given for lower range velocity limit are at the lowest LFCI setting.

Reference K-Factor

The reference K-factor is a coefficient that specifies the flowmeter calibration and is expressed as pulses per unit volume, where pulses/unit volume = pulses per second divided by volume flow per second.

The reference K-factor is the arithmetic mean value of K over the factory-calibrated flow range. It is determined at the factory by actual flow calibration with water by comparison to a master flowmeter calibration, or by actual static weight. Both calibrations are traceable to NIST. The reference K-factor is entered in the flowmeter database and stamped on the data plate. Once established, this K-factor is available to gas, liquid, or steam.

Flowing K-Factor

The flowing K-factor is computed from the K-reference expressed in specified flowing units, and can be corrected for the following:

- Process Temperature
- Mating Pipe
- Upstream Disturbances

Process Temperature Correction

The flowmeter computes a corrected K-factor at the specific process temperature entered by the user.

Process Temperature Effect on K-Factor

There is an effect on the reference K-factor due to a diameter change of the flowtube bore with temperature. The effect is -0.3% of flow rate per 100°F (55°C) increase in temperature. These flowmeters will automatically recompute a flowing K-factor when process temperature is entered in the database fluid definition.

K-Factor Bias

Provisions are made in the configuration menu to bias the flowmeter K-factor by a percent (%) value. Flowing K-factor value will be automatically recalculated when the % bias is entered.

Static Pressure Limits

MINIMUM STATIC PRESSURE

The minimum static pressure is that pressure which is sufficient to prevent flashing and meet the pressure drop requirements to attain maximum flow rate. For sizing tools, visit www.FlowExpertPro.com.

MAXIMUM STATIC PRESSURE

3750 psig (258.6 bar) (25855 kPa) or that imposed by flange rating. To determine the pressure drop for Model 84 Vortex flowmeters and use other sizing tools, visit www.FlowExpertPro.com.

FUNCTIONAL SPECIFICATIONS (CONT.)

Minimum Back Pressure (Volatile Liquids or Low Pressure Conditions)

Any condition that tends to contribute to the release of vapor from the liquid (flashing, which may also induce cavitation) shall be avoided by proper system design and operation of the flowmeter within the rated flow rate range. Location of flowmeter should consider the need for using a back-pressure valve, or for increasing inlet pressure. To avoid flashing and to ensure stable vortex generation, the minimum back pressure should be:

$$P_G = (3)(\Delta P) + (1.25)(p_v) - (p_{atm})$$

where,

- P_G = Gauge pressure in kPa or psi five pipe diameters downstream of the flowmeter
- ΔP = Pressure loss in psi or kPa
- p_v = Vapor pressure at line conditions in psi or kPa absolute
- p_{atm} = Atmospheric pressure in psi or kPa absolute

Flange Pressure-Temperature Ratings

See MI 019-202 and MI 019-211 for ANSI and DIN flange pressure-temperature ratings. These ratings are also embedded in the FlowExpertPro sizing tool. Also see Figure 6 for pressure-temperature limits when isolation valves are used. Also note the temperature limit when fluorolube fill (200°F/90°C) or silicone fill (400°F/200°C) is used, or when no fill (800°F/430°C) is used with extended temperature applications.

Isolation Valves

Flowmeters equipped with an isolation valve have Pressure-Temperature limits as shown in Figure 6.

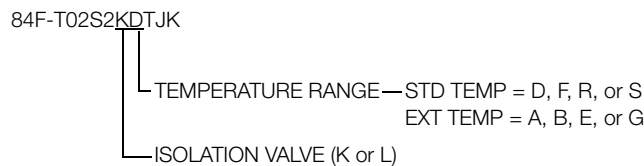

Functional Block Diagrams

Refer to Figure 4 and Figure 5.

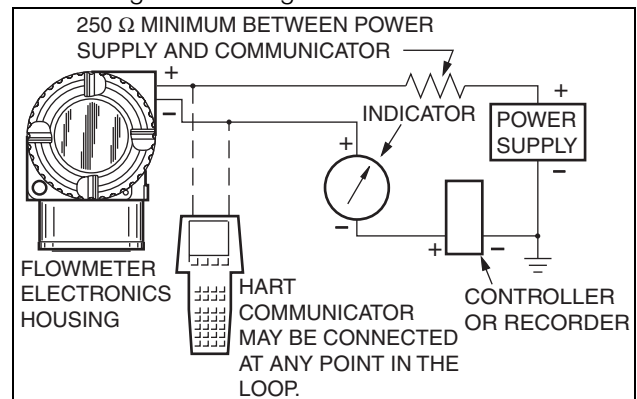

Figure 4. HART 4 to 20 mA Topology

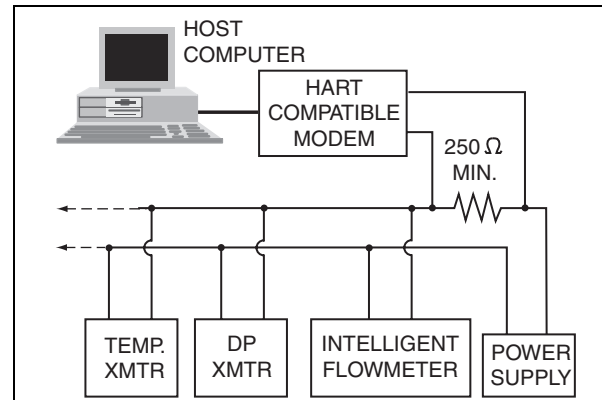

Figure 5. HART Multidrop Topology

The temperature range of your flowmeter is found within the model number on the data label as follows:

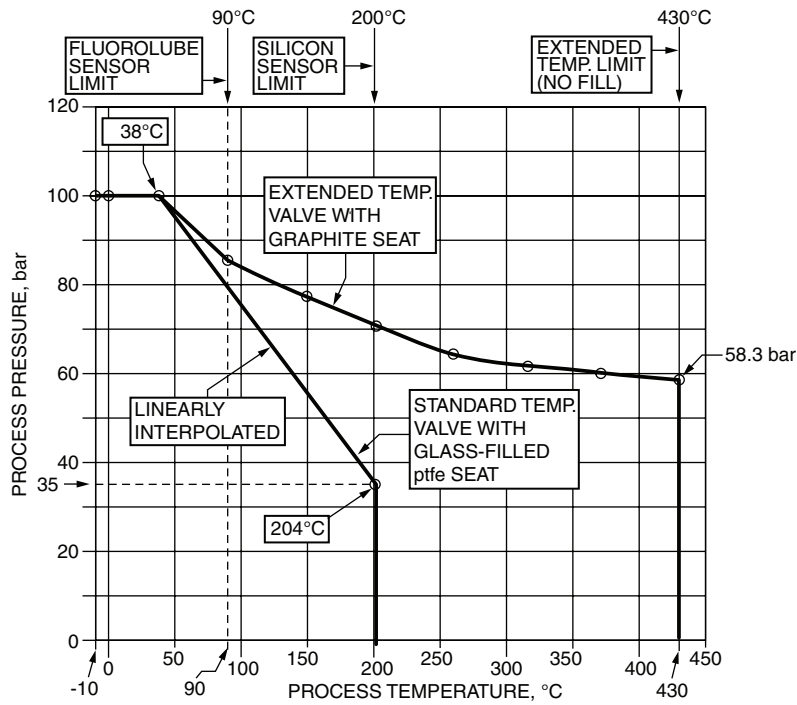
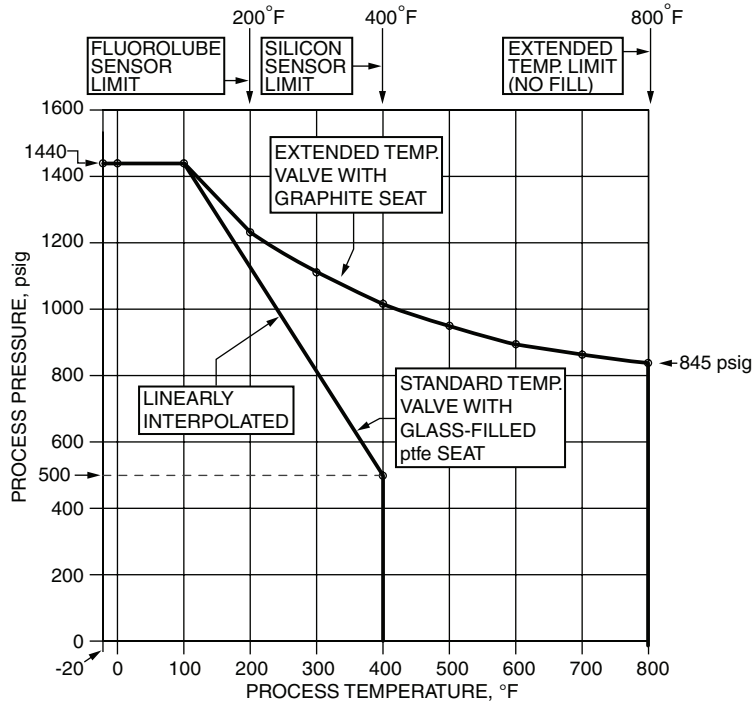

Figure 6. Pressure-Temperature Limits with Isolation Valves

PHYSICAL SPECIFICATIONS

Process-Wetted Parts - Model 84F (Style B)

FLOWMETER BODY, FLANGES, AND SHEDDING BAR (ALSO SEE MODEL CODE)

3/4" to 4" line size options:

- ▶ 316 SS (CF8M) Cast Body/Shedder and Type 316 SS Flanges
- ▶ 316 SS (CF8M) body and shedder and Carbon Steel flanges
- ▶ Duplex SS Cast Body/Shedder per ASTM A995, Grade 4A, CD3MN and Duplex SS Flanges per A 182 Grade F51
- ▶ CX2MW Cast Nickel Alloy Body/Shedder and Nickel Alloy N06022 Flanges

6" to 12" line size options:

- ▶ 316 SS (CF8M) Cast Body/Shedder and Type 304 SS Flanges
- ▶ 316 SS (CF8M) body and shedder and Carbon Steel flanges
- ▶ Duplex SS Cast Body/Shedder per ASTM A995, Grade 4A, CD3MN and Duplex SS Flanges per A 182 Grade F51
- ▶ CX2MW Cast Nickel Alloy Body/Shedder and Nickel Alloy N06022 Flanges

GASKETS AND FLOW DAM (SENSOR SEALS)

Standard Temperature Sensor

- ▶ ptfе gasket and flow dam

High Temperature Sensor

- ▶ 316 SS gasket; 316 SS/grafoil flow dam
- ▶ Nickel alloy CW2M (equivalent to Hastelloy^{®(a)} C-4C) gasket; Nickel alloy CW2M (equivalent to Hastelloy[®] C-4C)/grafoil flow dam

(a) Hastelloy[®] is a registered trademark of Haynes International Inc.

Dual Measurement Manifold

CF8M stainless steel; pressure and temperature rating of dual manifold same as flowmeter body.

Flowmeter Mounting

Flowmeter can be located in a pipeline which may run in any direction from the vertical (upward flow) to the horizontal. The electronics housing can also be rotated 270° (in 90° increments) with respect to the body. A vertical pipeline is preferred for batch operations to provide improved full line assurance. See Recommended Mounting Arrangements section.

Electrical Connections

Field wires enter through 1/2 NPT or M20 conduit threaded entrances on either side of the electronics housing. Wires terminate under screw terminals and washers on terminal block (see Figure 7) in the field terminal compartment. Unused entrance is plugged to insure moisture and RFI/EMI protection.

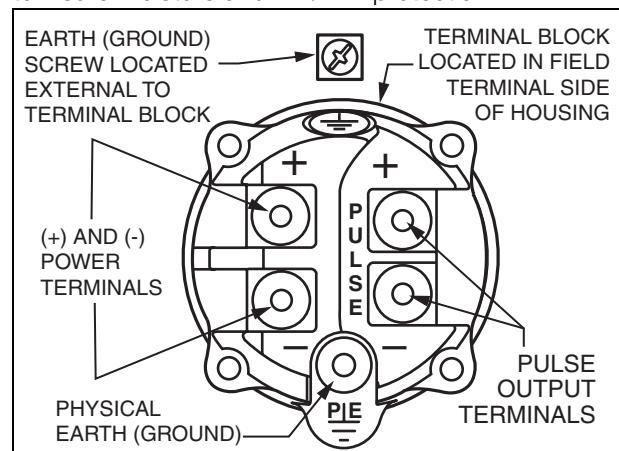

Figure 7. Terminal Block

Electronics Housing and Housing Covers

A two compartment housing separates the electronics from the field connections. Housing and covers are low copper, die-cast aluminum alloy with an epoxy finish. Buna-N O-ring seals are used to seal the housing covers, housing neck, and terminal block.

Electronics Module

Printed wiring assemblies (PWAs) are conformally coated for moisture and dust protection.

Environmental Protection

The electronics housing has the dusttight and weatherproof rating of IP66 as defined by IEC 60529, and provides the environmental and corrosion resistant protection rating of NEMA 4X.

PHYSICAL SPECIFICATIONS (CONT.)

Isolation Valve (if specified, see Model Code for Selection Options)

VALVE BODY

Grade CF8M stainless steel

VALVE BALL

316 SS

VALVE SEATS

Standard Temperature: Glass-Filled ptfe

Extended Temperature: Graphite

STEM SEAL

The valve stem seal meets the external leakage requirements for fire safety per API Standard 607.

VALVE HANDLE

Use adjustable wrench.

SEAT LEAKAGE

- Standard Temperature
Class IV – Less than 5 mL/h per MSS-SPG1.
- High Temperature
Class IV per ANSI/FCI-70.2

FLOW VELOCITY LIMITS

See “Flow Velocity Limits” section.

APPLICATIONS

Recommended for use with clean liquids, saturated steam, and all gases.

LIMITATIONS

Not recommended for use with superheated steam without insulation, or liquids with suspended solids.

MOUNTING

See MI 019-202 and MI 019-211 for installation guidelines.

PRESSURE/TEMPERATURE RATING

Both standard and extended (high) temperature isolation valves have a maximum pressure rating of 1440 psi at 100°F (100 bar at 38°C). The standard temperature valve with ptfe seats is further limited to a maximum pressure of 500 psi at 400°F (35 bar at 204°C). The extended temperature valve has an ANSI Class 600 temperature and pressure rating. See Figure 6.

Data Plate

Stainless steel data plate encircles and is secured to the lower part of the electronics housing. Includes conventional Model and operating data, including the factory calibration factor (K-factor). If additional tag data space is required, an optional Stainless Steel Customer Tag is offered.

NACE Certification

The Models 84F (Style B) flowmeters have been designed to meet the requirements of NACE Standard MR-0175-2003 for use in H₂S Sour Oilfield environments. The 316 SS, Duplex SS, and high-nickel alloy CX2MW process wetted materials have been selected to be NACE compliant. The design and process wetted materials also comply with NACE Standard MR-0103-2007 for use in corrosive Petroleum Refining environment. A NACE compliance certificate is available by selecting the -Q option.

Dimensions

Refer to Dimensions - Nominal section for general outline data. For more dimensional details, refer to the following Dimensional Prints (DPs).

Model	Configuration	Dimensional Print
84F	Single Measurement	DP 019-125
84F	Dual Measurement	DP 019-126

PHYSICAL SPECIFICATIONS (CONT.)

Approximate Weight

Table 3. Approximate Weight - Model 84F (Style B)

Model 84F (Style B) Flanged Body			
Nominal Line Size	Flange	Material	Weight, lb (Kg.) (a)
0.75 in	Class 150	316 SS	10.4 (4.71)
0.75 in	Class 150	Duplex SS	10.2 (4.62)
0.75 in	Class 150	Nickel alloy CX2MW (equivalent to Hastelloy®(b) C-22)	10.8 (4.90)
0.75 in	Class 1500	316 SS	19.3 (8.75)
0.75 in	Class 1500	Duplex SS	18.8 (8.53)
0.75 in	Class 1500	Nickel alloy CX2MW (equivalent to Hastelloy®(b) C-22)	20.5 (9.30)
1 in	Class 150	316 SS	12.2 (5.53)
1 in	Class 150	Duplex SS	12.0 (5.44)
1 in	Class 150	Nickel alloy CX2MW (equivalent to Hastelloy®(b) C-22)	12.8 (5.81)
1 in	Class 1500	316 SS	24.3 (11.02)
1 in	Class 1500	Duplex SS	23.6 (10.70)
1 in	Class 1500	Nickel alloy CX2MW (equivalent to Hastelloy®(b) C-22)	25.9 (11.75)
1.5 in	Class 150	316 SS	16.7 (7.57)
1.5 in	Class 150	Duplex SS	16.3 (7.39)
1.5 in	Class 150	Nickel alloy CX2MW (equivalent to Hastelloy®(b) C-22)	17.7 (8.03)
1.5 in	Class 1500	316 SS	34.5 (15.65)
1.5 in	Class 1500	Duplex SS	33.4 (15.15)
1.5 in	Class 1500	Nickel alloy CX2MW (equivalent to Hastelloy®(b) C-22)	36.9 (16.74)
2 in	Class 150	316 SS	20.9 (9.48)
2 in	Class 150	Duplex SS	20.4 (9.25)
2 in	Class 150	Nickel alloy CX2MW (equivalent to Hastelloy®(b) C-22)	22.2 (10.07)
2 in	Class 1500	316 SS	54.2 (24.58)
2 in	Class 1500	Duplex SS	52.5 (23.81)
2 in	Class 1500	Nickel alloy CX2MW (equivalent to Hastelloy®(b) C-22)	58.2 (26.40)
3 in	Class 150	316 SS	43.0 (19.50)
3 in	Class 150	Duplex SS	41.7 (18.91)
3 in	Class 150	Nickel alloy CX2MW (equivalent to Hastelloy®(b) C-22)	46.2 (20.96)
3 in	Class 1500	316 SS	109.7 (49.76)
3 in	Class 1500	Duplex SS	106.1(48.13)
3 in	Class 1500	Nickel alloy CX2MW (equivalent to Hastelloy®(b) C-22)	118.4 (53.71)
4 in	Class 150	316 SS	46.4 (21.05)
4 in	Class 150	Duplex SS	45.0 (20.41)
4 in	Class 150	Nickel alloy CX2MW (equivalent to Hastelloy®(b) C-22)	49.9 (22.63)
4 in	Class 1500	316 SS	155.9 (70.72)
4 in	Class 1500	Duplex SS	150.7 (68.36)
4 in	Class 1500	Nickel alloy CX2MW (equivalent to Hastelloy®(b) C-22)	168.4 (76.38)

Table 3. Approximate Weight - Model 84F (Style B) (Continued)

Model 84F (Style B) Flanged Body			
Nominal Line Size	Flange	Material	Weight, lb (Kg.) ^(a)
6 in	Class 150	316 SS	77.6 (35.2)
6 in	Class 150	Duplex SS	75.1 (34.0)
6 in	Class 150	Nickel alloy CX2MW (equivalent to Hastelloy ^{®(b)} C-22)	83.6 (37.92)
6 in	Class 150	CS	81.1 (36.78)
6 in	Class 600	316 SS	178.1 (77.92)
6 in	Class 600	Duplex SS	175.5 (79.6)
6 in	Class 600	Nickel alloy CX2MW (equivalent to Hastelloy ^{®(b)} C-22)	204.0 (92.53)
6 in	Class 600	CS	186.5 (84.59)
6 in	Class 1500	316 SS	357.0 (161.93)
6 in	Class 1500	Duplex SS	344.9 (156.44)
6 in	Class 1500	Nickel alloy CX2MW (equivalent to Hastelloy ^{®(b)} C-22)	386.1 (175.13)
6 in	Class 1500	CS	349.0 (158.3)
8 in	Class 150	316 SS	127.3 (57.74)
8 in	Class 150	Duplex SS	123.1 (55.83)
8 in	Class 150	Nickel alloy CX2MW (equivalent to Hastelloy ^{®(b)} C-22)	137.4 (62.32)
8 in	Class 150	CS	125.1(56.74)
8 in	Class 600	316 SS	289.4 (131.26)
8 in	Class 600	Duplex SS	279.6 (126.82)
8 in	Class 600	Nickel alloy CX2MW (equivalent to Hastelloy ^{®(b)} C-22)	312.9 (141.92)
8 in	Class 600	CS	283.3 (128.5)
8 in	Class 1500	316 SS	657.2 (298.1)
8 in	Class 1500	Duplex SS	634.7 (287.89)
8 in	Class 1500	Nickel alloy CX2MW (equivalent to Hastelloy ^{®(b)} C-22)	711.1 (322.54)
8 in	Class 1500	CS	642.5 (291.43)
10 in	Class 150	316 SS	160.0 (72.57)
10 in	Class 150	Duplex SS	154.7 (70.17)
10 in	Class 150	Nickel alloy CX2MW (equivalent to Hastelloy ^{®(b)} C-22)	172.9 (78.42)
10 in	Class 600	316 SS	476.2 (216.0)
10 in	Class 600	Duplex SS	460.0 (208.65)
10 in	Class 600	Nickel alloy CX2MW (equivalent to Hastelloy ^{®(b)} C-22)	515.2 (233.69)
12 in	Class 150	316 SS	252.4 (114.48)
12 in	Class 150	Duplex SS	243.8 (110.58)
12 in	Class 150	Nickel alloy CX2MW (equivalent to Hastelloy ^{®(b)} C-22)	272.8 (123.73)
12 in	Class 600	316 SS	540.4 (245.12)
12 in	Class 600	Duplex SS	521.9 (236.72)
12 in	Class 600	Nickel alloy CX2MW (equivalent to Hastelloy ^{®(b)} C-22)	584.7 (265.21)
DN15	PN40	316 SS	12.3 (5.58)
DN15	PN40	Duplex SS	12.1 (5.49)
DN15	PN40	Nickel alloy CX2MW (equivalent to Hastelloy ^{®(b)} C-22)	12.9 (5.85)

Table 3. Approximate Weight - Model 84F (Style B) (Continued)

Model 84F (Style B) Flanged Body			
Nominal Line Size	Flange	Material	Weight, lb (Kg.) ^(a)
DN15	PN100	316 SS	16.2 (7.35)
DN15	PN100	Duplex SS	15.8 (7.17)
DN15	PN100	Nickel alloy CX2MW (equivalent to Hastelloy ^{®(b)} C-22)	17.1 (7.76)
DN25	PN40	316 SS	13.4 (6.08)
DN25	PN40	Duplex SS	13.1 (5.94)
DN25	PN40	Nickel alloy CX2MW (equivalent to Hastelloy ^{®(b)} C-22)	14.1 (6.40)
DN25	PN160	316 SS	19.1 (8.66)
DN25	PN160	Duplex SS	18.6 (8.44)
DN25	PN160	Nickel alloy CX2MW (equivalent to Hastelloy ^{®(b)} C-22)	20.3 (9.21)
DN40	PN40	316 SS	17.9 (8.12)
DN40	PN40	Duplex SS	17.5 (7.94)
DN40	PN40	Nickel alloy CX2MW (equivalent to Hastelloy ^{®(b)} C-22)	19.0 (8.62)
DN40	PN160	316 SS	28.2 (12.79)
DN40	PN160	Duplex SS	27.4 (12.43)
DN40	PN160	Nickel alloy CX2MW (equivalent to Hastelloy ^{®(b)} C-22)	30.1 (13.65)
DN50	PN40	316 SS	21.7 (9.84)
DN50	PN40	Duplex SS	21.2 (9.62)
DN50	PN40	Nickel alloy CX2MW (equivalent to Hastelloy ^{®(b)} C-22)	23.1 (10.48)
DN50	PN160	316 SS	38.4 (17.42)
DN50	PN160	Duplex SS	37.3 (16.92)
DN50	PN160	Nickel alloy CX2MW (equivalent to Hastelloy ^{®(b)} C-22)	41.2 (18.69)
DN80	PN40	316 SS	33.3 (15.10)
DN80	PN40	Duplex SS	32.3 (14.65)
DN80	PN40	Nickel alloy CX2MW (equivalent to Hastelloy ^{®(b)} C-22)	35.6 (16.15)
DN80	PN160	316 SS	58.6 (26.58)
DN80	PN160	Duplex SS	56.7 (25.72)
DN80	PN160	Nickel alloy CX2MW (equivalent to Hastelloy ^{®(b)} C-22)	63.0 (28.58)
DN100	PN40	316 SS	44.4 (20.14)
DN100	PN40	Duplex SS	43.1 (19.55)
DN100	PN40	Nickel alloy CX2MW (equivalent to Hastelloy ^{®(b)} C-22)	47.7 (21.64)
DN100	PN160	316 SS	81.2 (36.83)
DN100	PN160	Duplex SS	78.6 (35.65)
DN100	PN160	Nickel alloy CX2MW (equivalent to Hastelloy ^{®(b)} C-22)	87.5 (39.69)
DN150	PN16	316 SS	61.5 (27.89)
DN150	PN16	Duplex SS	59.5 (26.98)
DN150	PN16	Nickel alloy CX2MW (equivalent to Hastelloy ^{®(b)} C-22)	66.1 (29.98)
DN150	PN16	CS	60.5 (27.44)
DN150	PN160	316 SS	195.8 (88.81)
DN150	PN160	Duplex SS	189.2 (85.81)

Table 3. Approximate Weight - Model 84F (Style B) (Continued)

Model 84F (Style B) Flanged Body			
Nominal Line Size	Flange	Material	Weight, lb (Kg.) ^(a)
DN150	PN160	Nickel alloy CX2MW (equivalent to Hastelloy ^{®(b)} C-22)	211.6 (95.98)
DN150	PN160	CS	191.7 (86.95)
DN200	PN16	316 SS	94.8 (43)
DN200	PN16	Duplex SS	88.2 (40)
DN200	PN16	Nickel alloy CX2MW (equivalent to Hastelloy ^{®(b)} C-22)	102.2 (46.35)
DN200	PN16	CS	93.4 (42.36)
DN200	PN160	316 SS	356.7 (161.79)
DN200	PN160	Duplex SS	344.6 (156.3)
DN200	PN160	Nickel alloy CX2MW (equivalent to Hastelloy ^{®(b)} C-22)	385.8 (174.99)
DN200	PN160	CS	349.3 (158.43)
DN250	PN16	316 SS	143.6 (65.13)
DN250	PN16	Duplex SS	138.8 (62.95)
DN250	PN16	Nickel alloy CX2MW (equivalent to Hastelloy ^{®(b)} C-22)	155.1 (70.35)
DN250	PN100	316 SS	421.6 (191.23)
DN250	PN100	Duplex SS	407.2 (184.70)
DN250	PN100	Nickel alloy CX2MW (equivalent to Hastelloy ^{®(b)} C-22)	456.0 (206.83)
DN300	PN16	316 SS	204.4 (92.71)
DN300	PN16	Duplex SS	197.5 (89.58)
DN300	PN16	Nickel alloy CX2MW (equivalent to Hastelloy ^{®(b)} C-22)	220.9 (100.19)
DN300	PN100	316 SS	618.0 (280.32)
DN300	PN100	Duplex SS	596.9 (270.74)
DN300	PN100	Nickel alloy CX2MW (equivalent to Hastelloy ^{®(b)} C-22)	668.7 (303.31)

(a) Notes:

- The weights shown are approximate and are meant as a guide to the user.
- Standard temperature flowmeter weights are listed for integrally mounted electronics housings. There is a slight weight difference for high temperature flowmeters (adds about 1 lb (0.5 kg)), or for remote mounted housings (housing replaced by connector head assembly (junction box)). The electronics housing itself weighs about 4 lbs (2 kg) and varies slightly depending on whether indicator/configurator, and/or extended housing covers are used.
- For single measurement flowmeters, add approximately 2 lb (1 kg) if an isolation valve is used.
- For dual measurement flowmeters (applicable to 84F (Style B) flowmeters only):
 - Add approximately 9 lb (4 kg) when a manifold without isolation valves is used.
 - Add approximately 15 lb (7 kg) when a manifold with two isolation valves is used.

(b) Hastelloy[®] is a registered trademark of Haynes International Inc.

Table 4. Body Internal Dimensions – Body Style F-Flanged (Style B) for Schedule 80 Bore^(a)

ANSI/DIN Nominal Line Size		Bore (ID)	
in	mm	in	mm
0.75	15	0.74	18.8
1.00	25	0.96	24.3
1.50	40	1.50	38.1
2.00	50	1.94	49.2
3.00	80	2.87	72.9
4.00	100	3.83	97.2
6.00	150	5.76	146.3
8.00	200	7.63	193.7
10.00	250	9.56	242.9
12.00	300	11.38	288.9

- (a) Dimensions are for following flange offerings:
- 3/4"-1.5": ANSI Class 150-1500
 - DN15-DN40: PN40-PN160
 - 2"-4": ANSI Class 150-900
 - DN50-DN100: PN40-PN160
 - 6"-12": ANSI Class 150-600
 - DN150-300: PN16-PN100

Table 5. Body Internal Dimensions – Body Style F-Flanged (Style B) for Schedule 160 Bore^(a)

ANSI/DIN Nominal Line Size		Bore (ID)	
in	mm	in	mm
2.00	50	1.69	42.8
3.00	80	2.63	66.7
4.00	100	3.44	87.3
6.00	150	5.19	131.8
8.00	200	6.81	173.1

- (a) Dimensions are for following flange offerings:
- 2"-4": ANSI Class 1500
 - 6"-8": ANSI Class 900-1500
 - DN150-200: PN160

Agency, Types of Protection, and Area Classification	Application Conditions	Elect. Safety Design Code
FM intrinsically safe for Class I, II, III, Div. 1, Groups A, B, C, D, E, F, G. Also, Zone approved AEx ia IIC	Temperature Class T4; Ta = 80°C	F
FM explosionproof with IS sensor connection for Class I, Div. 1, Groups B, C, and D; dust-ignitionproof for Class II, Div. 1, Groups E, F, and G; Class III, Div. 1	Temperature Class T5; Ta = 85°C	G
FM nonincendive for Class I, Div. 2, Groups A, B, C, and D; Class II, Div. 2, Groups F and G; Class III, Div. 2	Temperature Class T4; Ta = 80°C	K
IECEx intrinsically safe: Ex ia IIC T4 Ga Ex tb IIIC T103°C Db (See note 1)	Temperature Class T4; Ta = -40° to +80°C	L
IECEx flameproof: Ex d [ia Ga] ia IIC T4 Gb Ex tb IIIC T85°C Db (See note 1)	Integrally mounted electronics. Temperature Class T4; Ta = -20° to +80°C	B
IECEx flameproof: Ex d [ia Ga] IIC T4 Gb Ex tb IIIC T85°C Db (See note 1)	Electronic housing of remote mounted version. Temperature Class T4; Ta = -20° to +80°C	
NEPSI intrinsically safe, Zone 0, Ex ia IIC (See note 1)	Temperature Class T4; Ta = -40° to +80°C	R
NEPSI flameproof, Zone 1, Ex d IIC (except acetylene) (See note 1)	Temperature Class T5; Ta = -40° to +85°C	S
Unit with CE mark and PED controls and records (See note 1)		Y
Unit does not have CE mark; not to be installed in European Union (EU) countries		Z

- (1) The Model 84 (Style B) has been designed to meet the electrical safety descriptions listed above. For detailed information, or status of the testing laboratory approval/certification, contact Invensys.
- (2) With intrinsically safe approvals and certifications with a 24 V dc supply, an active barrier is required.
- (3) Refer to MI 019-177 for FM and CSA Connection Diagrams.
- (4) Refer to MI 019-179 for ATEX and IECEx Safety Information.
- (5) As stated in the OPERATING CONDITIONS table, when the LCD Indicator is used, the low temperature limit is -20°C.

RECOMMENDED MOUNTING ARRANGEMENTS

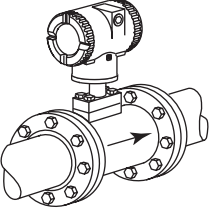
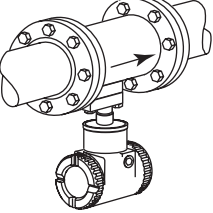
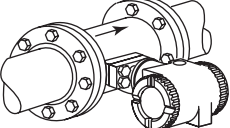
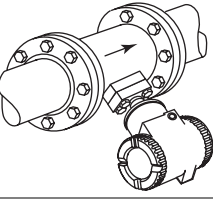
Flowmeter Mounting Arrangement Model 84F (Style B) Single Measurement Flowmeter Shown (For Dual Measurement Flowmeters, refer to the associated MI for mounting arrangements)		Flowmeter for Use With:			
		Liquid	Gas	Saturated Steam	Superheated Steam
	Housing Above Pipe; Isolation Valve and Dual Measurement Flowmeter NOT Used	Yes (1)	Yes	No	Yes (2)
	Housing Above Pipe; Isolation Valve and Dual Measurement Flowmeter CAN be Used	No (5)	Yes	No	Yes (2)
	Housing Below Pipe	Yes (3) (4) (6)	Yes (4)	Yes	Yes (2)
	Housing to Side of Pipe	Yes	Yes	No	Yes (2)
	Housing to Side and Below Pipe	Yes (6)	Yes	No	Yes (2)

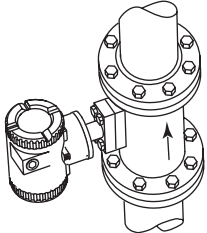
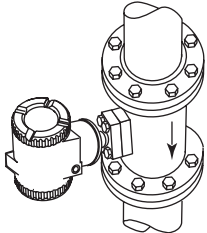
Flowmeter Mounting Arrangement Model 84F (Style B) Single Measurement Flowmeter Shown (For Dual Measurement Flowmeters, refer to the associated MI for mounting arrangements)		Flowmeter for Use With:			
		Liquid	Gas	Saturated Steam	Superheated Steam
	Vertical Pipe, Flow upward	Yes	Yes	No	Yes (2)
	Vertical Pipe, Flow Downward	Yes (7)	Yes	No	Yes (2)

- (1) Possibility of temporary start-up error due to trapped air.
- (2) Requires adequate insulation.
- (3) Best choice when errors due to start-up cannot be tolerated.
- (4) Recommended only for clean fluids.
- (5) Not recommended for liquids with isolation valve.
- (6) Preferred for liquids with isolation valve.
- (7) Not preferred; must maintain full pipe with no voids in fluid.

OPTIONAL SELECTIONS AND ACCESSORIES

Options -B, -D, -E, -G: Cable Assembly to Remote Electronics Housing

When selecting Code -R for a Remote Mounted Housing, a cable length must be selected. Four cable lengths are offered as follows:

Option	Cable Length
-B	20 ft (6 m)
-D	30 ft (9 m)
-E	40 ft (12 m)
-G	50 ft (15 m)

Option -H: Cleaning for Oxygen or Chlorine Gas Service

Process wetted parts are cleaned for oxygen or chlorine service in compliance with Compressed Gas Association's CGA-4.1 and ASTM G93. Cleaning is not offered when an isolation valve, or dual measurement or extended temperature meters are selected. Select Option -H.

Option -J: Gold Plated Sensor

This option is recommended for H₂ (Hydrogen) processes. Select Option -J.

Options -L, -M, -Q: Foxboro Certificates of Conformance and Compliance

Three material certificates are offered. Option -L provides a certificate of compliance to Invensys specifications. The Invensys quality system conforms to ISO 9001. Option -M is a certification of material for process wetted metal (conforms to BS EN 10204 3.1). Option -Q certifies that stainless steel materials meet NACE Std. MR-01.

Option -N: Certified Calibration Certificate

A calibration and pressure test sheet come standard with each flowmeter. A certified flow calibrated K-factor and pressure test certificate is available by selecting Option -N.

Options -F, -V, -X: Welding Certificates – With Flanged Body Flowtubes Only

Four certificates are available. Option -F certifies that the fabrication of flowtubes by welders is to ASME Boiler Code, Section IX. Temperature Options -E and -G are high temperature options (400°F to 800°F or 200°C to 430°C); both of these high temperature options require Welding Certificate Option -X. It includes radiographic examination of welds for Nominal Line Size selection (03 to 12). Option -V provides radiographic examination and certification of circumferential welds, and Option -X certifies that welding is per ASME Boiler Code, Section IX and Radiographic Examination.

Option -P: Cable Connector - Hawke-Type Cable Gland

Brass cable gland with 1/2 NPT external thread. Provides support for field cable. Ensure that this cable connector is qualified to meet the electrical safety specification selected. See Electrical Safety Specification section. Available with Electrical Housing Codes T and R only (1/2 NPT). Select Option -P.

Option -R: Cable Connector - PG11 Cable Gland

A PG11 cable gland with 1/2 NPT external thread. Provides strain relieved support for field cable. The PG11 is for cable diameters from 8 to 12 mm. Ensure that this cable connector is qualified to meet the electrical safety specification selected. See Electrical Safety Specification section. Available with Electrical Housing Codes T and R only (1/2 NPT). Select Option -R.

OPTIONAL SELECTIONS AND ACCESSORIES (CONT.)

Option -T: Conduit Fitting

A conduit fitting is available with Remote Mounting Code R only. It is provided when conduit is used to enclose the cable between the flowtube body and remote transmitter. Both ends of the fitting are 1/2 NPT and interconnect the conduit and transmitter at the housing and flowtube ends. Specify Option -T.

AS Code MTS: Stainless Steel Customer Tag Accessory

A 1.5 x 3.5 in (40 x 90 mm) stainless steel tag for customer data that does not fit on the standard plate. It is fastened to housing with wire. Accommodates 10 lines of data with 40 characters/spaces per line. Tag will also show customer's K-factor (information with flowing conditions being submitted to Invensys with sales order). Specify AS Code MTS.

MODEL CODES

Model 84F (Style B) Intelligent Vortex Flowmeters – Flanged Body

<u>Description</u>	<u>Model</u>
Intelligent Vortex Flowmeter – Flanged Body	84F
<u>Electronics Version</u>	
Intelligent Electronics, HART Communication Protocol, with Pulse Output	-T
Intelligent Electronics, HART Communication Protocol, without Pulse Output	-U
Intelligent Electronics, Low Power HART Communication Protocol, with Pulse Output (h)	-L
Intelligent Electronics, Low Power HART Communication Protocol, without Pulse Output (h)	-M
<u>Nominal Line Size</u>	
3/4 in (DN15) Line Size	3Q
1 in (DN25) Line Size	01
1 1/2 in (DN40) Line Size	1H
2 in (DN50) Line Size	02
3 in (DN80) Line Size	03
4 in (DN100) Line Size	04
6 in (DN150) Line Size (e)	06
8 in (DN200) Line Size (e) (l)	08
10 in (DN250) Line Size (e)	10
12 in (DN300) Line Size (e)	12
<u>Body, Flange, and Shedder Bar Material</u>	
CF8M 316 SS Cast Body/Shedder and Type 316 SS Flanges (Line Sizes 3Q to 04) and Type 304 SS Flanges (Line Sizes 06 to 12)	R
CF8M 316SS Cast Body/Shedder and Type 316 SS Flanges (Line Sizes 3Q to 04) and Type 304 SS Flanges (Line Sizes 06 to 12) (Face-to-face lengths are backward compatible with Style A Model 84 Vortex Flowmeters)	Y
(i) (j) CF8M 316 SS Cast Body/Shedder and A105 Carbon Steel Flanges	J
Duplex SS Cast Body/Shedder per ASTM A 995, Grade 4A, CD3MN and Duplex SS Flanges per A182 Grade F51 (e)	D
CX2MW Cast Nickel Alloy (equivalent to Hastelloy [®] C-22) Body/Shedder and Nickel Alloy N06022 Flanges (e)	H

MODEL CODES (CONT.)

Model 84F (Style B) Intelligent Vortex Flowmeters - Flanged Body (Cont.)

<u>Description (Cont.)</u>	<u>Model</u>
<u>End Connections and Flange Rating</u>	
ANSI Class 150 RF	1
ANSI Class 300 RF	2
ANSI Class 600 RF	3
ANSI Class 900 RF (Not Available with Line Sizes 10 and 12)	4
ANSI Class 1500 RF (Not Available with Line Sizes 10 and 12)	9
ANSI Class 150 RTJ (Not Available with Line Size 3Q)	N
ANSI Class 300 RTJ	P
ANSI Class 600 RTJ	R
ANSI Class 900 RTJ (Not Available with Line Sizes 10 and 12)	S
ANSI Class 1500 RTJ (Not Available with Line Sizes 10 and 12)	T
PN16 EN1092-1 Raised Face Type "D" Nut Groove (Available with Line Sizes 06 through 12 only)	5
PN25 EN1092-1 Raised Face Type "D" Nut Groove (Available with Line Sizes 08 through 12 only)	J
PN40 EN1092-1 Raised Face Type "D" Nut Groove	6
PN63 EN1092-1 Raised Face Type "D" Nut Groove (g)	7
PN100 EN1092-1 Raised Face Type "D" Nut Groove	8
PN160 EN1092-1 Raised Face Type "D" Nut Groove (Not Available with Line Sizes 3Q, 10, and 12)	K
PN16 EN1092-1 Raised Face Finish Type B1 (Available with Line Sizes 06 through 12 only)	D
PN25 EN1092-1 Raised Face Finish Type B1 (Available with Line Sizes 08 through 12 only)	L
PN40 EN1092-1 Raised Face Finish Type B1	F
PN63 EN1092-1 Raised Face Finish Type B2 (c)	G
PN100 EN1092-1 Raised Face Finish Type B2	H
PN160 EN1092-1 Raised Face Finish Type B2 (Not Available with Line Sizes 3Q, 10, and 12)	M
<u>Single or Dual Measurement; Isolation Valve and Manifold</u>	
Single Measurement; No Isolation Valve	S
Dual Measurement; Manifold with no Isolation Valves	D
Single Measurement; Manifold with one Isolation Valve; CF8M (316 SS); Not Available with End Connections 4, 9, H, K, M, S, and T (e)	K
Dual Measurement; Manifold with two Isolation Valves; CF8M (316 SS); Not Available with End Connections 4, 9, H, K, M, S, and T (e)	L
<u>Sensor Fill, Temperature Range, and Material</u>	
Standard Temperature Range (with Fill Fluid)	
Fluorolube Fill, 0° to 200°F (-20° to +90°C) Nickel alloy CW2M (equivalent to Hastelloy® C-4C (k))	D
Fluorolube Fill, 0° to 200°F (-20° to +90°C) Stainless Steel Type CF3M	F
Silicone Fill, 0° to 400°F (-20° to +200°C) Nickel alloy CW2M (equivalent to Hastelloy® C-4C (k))	R
Silicone Fill, 0° to 400°F (-20° to +200°C) Stainless Steel Type CF3M	S
<u>Extended Temperature Range (No Fill Fluid) (d)(f)</u>	
Unfilled, 400° to 700°F (200° to 370°C) Nickel alloy CW2M (equivalent to Hastelloy® C-4C (k))	A
Unfilled, 400° to 700°F (200° to 370°C) Stainless Steel Type CF3M	B
Unfilled, 400° to 800°F (200° to 430°C) Nickel alloy CW2M (equivalent to Hastelloy® C-4C(k))	E
Unfilled, 400° to 800°F (200° to 430°C) Stainless Steel Type CF3M	G

MODEL CODES (CONT.)

Model 84F (Style B) Intelligent Vortex Flowmeters - Flanged Body (Cont.)

Description (Cont.)	Model
Electronics Housing Mounting, Material, and Conduit Connections	
Integral Top Mounted 1/2-NPT Conduit Connections	T
Integral Top Mounted M20 Conduit Connections (b)	V
Remote Mounted 1/2-NPT Conduit Connections (a)	R
Remote Mounted M20 Conduit Connections (a)(b)	W
Local Digital Indicator/Configurator	
No Digital Indicator/Configurator (Blind Unit)	N
Full Function Digital Indicator/Configurator	J
Electrical Safety (Also see Electrical Safety Specifications section for further details)	
ATEX intrinsically Safe; II 1G II 2D Ex ia IIC T4 Ga Ex tb IIIC T103°C Db; not available with Mounting Codes T and R	E
ATEX flameproof; not available with Mounting Codes T and R:	H
▶ II 2/1 (1) G II 2D Ex d [ia Ga] ia IIC T4 Gb Ex tb IIIC T85°C Db; available with Mounting Code V only	
▶ II 2/1 (1) G II 2D Ex d [ia Ga] IIC T4 Gb Ex tb IIIC T85°C Db; available with Mounting Code W only	
▶ II 1G II 2D Ex ia IIC T4 Ga Ex tb IIIC T103°C Db; available with Mounting Code W only	
CSA intrinsically safe; Division 1; also zone certified Ex ia IIC	C
CSA nonincendive; Division 2	M
CSA explosionproof; Division 1	D
FM intrinsically safe; Division 1; also zone approved AEx ia IIC	F
FM nonincendive; Division 2	K
FM explosionproof; Division 1	G
IECEx intrinsically safe; Ex ia IIC T4 Ga Ex tb IIIC T103°C Db; not available with Mounting Codes T and R	L
IECEx flameproof; not available with Mounting Codes T and R:	B
▶ Ex d [ia Ga] ia IIC T4 Gb Ex tb IIIC T85°C Db; available with Mounting Code V only	
▶ Ex d [ia Ga] IIC T4 Gb Ex tb IIIC T85°C Db; available with Mounting Code W only	
▶ Ex ia IIC T4 Ga Ex tb IIIC T103°C Db; available with Mounting Code W only	
NEPSI intrinsically safe, Zone 0, Ex ia IIC; not available with Mounting Codes T and R	R
NEPSI flameproof, Zone 1, Ex d IIC; not available with Mounting Codes T and R	S
No Agency Electrical Certifications; with CE mark, PED Controls and Records	Y
No Agency Certifications; no CE mark; Units not to be installed in European Union (EU) countries	Z
Optional Selections	
Cable Length Selection for Remote Electronics Housing	
20 ft (6 m) Cable to Connect to Remote Electronics Housing	-B
30 ft (9 m) Cable to Connect to Remote Electronics Housing	-D
40 ft (12 m) Cable to Connect to Remote Electronics Housing	-E
50 ft (15 m) Cable to Connect to Remote Electronics Housing	-G
Cleaning - Oxygen/Chlorine Service	
Cleaning of Process Wetted Parts per Compressed Gas Association's CGA G-4.1 and ASTM G93	-H
- Available only with Body/Flange/Shedder Material Codes R and Y.	
- Not available with Line Sizes 10 and 12 or with Isolation Valve Codes D, K, and L.	
- Not available with Extended Temperature Codes E and G.	

MODEL CODES (CONT.)

Model 84F (Style B) Intelligent Vortex Flowmeters - Flanged Body (Cont.)

<u>Description (Cont.)</u>	<u>Model</u>
Optional Selections (Cont.)	
Sensor Plating Gold Plated Sensor	-J
Foxboro Certificates of Compliance/Conformance Standard Certificate of Compliance	-L
Foxboro Material Certification of Process Wetted Metal (Conforms to BS EN 10204 3.1)	-M
Process Wetted Parts Conform to NACE Standard MR-01	-Q
Foxboro Calibration Certificate Calibration and Pressure Test Certified Copy	-N
Cable Connectors – with Electrical Housing Codes T and R only (1/2 NPT) Hawke-Type Cable Gland (Available only with Electrical Safety Codes E, H, Y, and Z)	-P
PG11 Cable Gland, Trumpet Shaped (Not available with explosionproof/flameproof certifications)	-R
Conduit Fitting Adapter for use with 1/2 NPT conduit (Available only with Remote Mounted Housing Code R)	-T
Welding Certificate Welding certified to conform to ASME Boiler and Pressure Vessel Code, Section IX Radiographic Examination (X-Ray) of Flange Welds	-F -V
Welding certified to conform to ASME Boiler and Pressure Vessel Code, Section IX and Radiographic Examination (X-Ray) of welds	-X
Instruction Manual Detailed Instruction Manual in place of Universal MI 019-146	-C
Examples: 84F-T02S1SDTNK-X; 84F-T06K7DCRJE-GQNT	

- (a) For remote mounting, select optional cable length.
- (b) For ATEX and IECEx certifications, select M20.
- (c) For Line Sizes 3Q, 01, and 1H, select End Connection H.
- (d) See Welding Certificate Option -X for extended temperature range (400° to 800° F) (200° to 430° C).
- (e) Contact Invensys for availability in Style B.
- (f) High Temperature Sensors are not available with Body, Flange, and Shedder Bar Material selection D (Duplex SS).
- (g) For Line Sizes 3Q, 01, and 1H, select End Connection 8.
- (h) Only electrical certifications F, K, and G are available with these model codes at this time.
- (i) Available with ANSI End Connections 1, 2 and 3 for Line Sizes 3Q through 08, and End Connections 1 and 2 for Line Sizes 10 and 12.
- (j) These versions should only be used when replacing a Model 84F Style A meter or for stocking purposes for Model 84F Style A meters.
- (k) Hastelloy® is a registered trademark of Haynes International Inc.
- (l) For Line Size 08 with 4, 9, S, T, K, and M End Connections, Welding Certificate Option -X is required.

SUGGESTED RFQ SPECIFICATIONS FOR VORTEX FLOWMETER

The manufacturer shall provide field-mounted vortex flowmeters featuring digital signal processing techniques capable of accurately measuring liquid, gas, or steam flows. The specifications for these meters are as follows:

Communication Protocol:	HART
Outputs:	Analog (4 to 20 mA) and digital, with or without pulse output
Remote Communications:	Direct digital with HART Multidrop
Configuration:	Can be configured from the LCD indicator, HART communicator, or PC-based configurator
Accuracy:	0.5% of reading in liquids, 1.0% of reading in gas and steam
Internal Flow Totalizer:	Standard
Sensor:	Replaceable without meter recalibration required
EMC Compatibility:	Complies with International and European Union 61326 standards
EMI and RFI:	The flowmeter the EMI and RFI requirements for EN 61326-1
Voltage Supply:	2-wire 24 V dc loop powered
Power Supply:	10 to 42 V dc
Supply Current:	10 mA dc nominal
Mounting:	Electronics to accommodate integral or remote mounting
Electronics Housing:	Aluminum housing with epoxy finish 84 F (Style B); Remote or integrally mounted to flowtube. With remote mount, interconnecting cable up to 50 ft (15 m) required
Electronics:	Enclosed in a NEMA 4X/IP66 rated housing sealed with O-rings for protection against moisture or other contaminants, optional integral LCD indicator with on-board configuration pushbuttons
Body and Shedder Bar	316 or 304 stainless steel, Nickel alloy CX2MW (equivalent to Hastelloy® C-22 ^(a)),
Materials:	Duplex SS, or Carbon Steel
Flowmeter Sizing:	Foxboro sizing tools with free web site access at www.FlowExpertPro.com
Electrical Classification:	Must be suitable for Class I Division 1, Class I Division 2, ATEX zone 1, or ATEX zone 2 hazardous locations, and conform to applicable European Union directives
Model Code:	Foxboro Brand I/A Series Models 84F (Style B) Series Vortex Flowmeters, or equivalent

(a) Hastelloy® is a registered trademark of Haynes International Inc.

DIMENSIONS – NOMINAL
 $\frac{\text{mm}}{\text{in}}$

84F (Style B) FLANGED BODY FLOWMETERS; INTEGRAL MOUNT; SINGLE MEASUREMENT

84F (Style B) FLANGED BODY

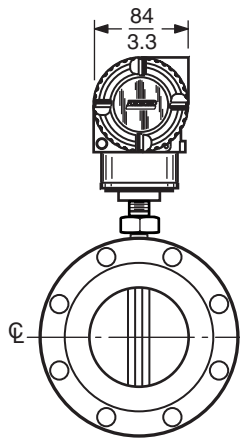

84F (Style B) FLANGED BODY

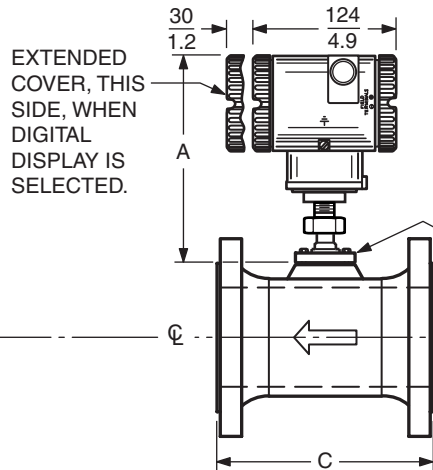

84F (Style B) WITH ISOLATION VALVE

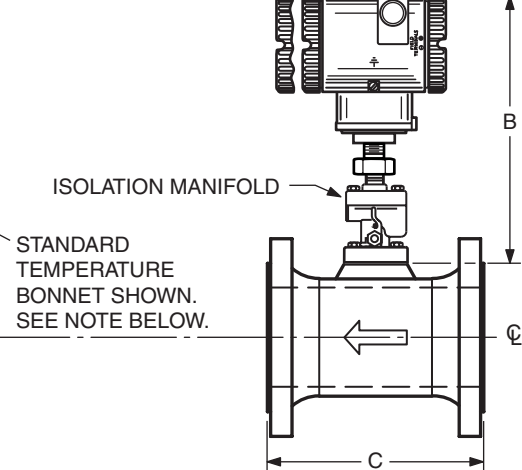

84F (Style B) Flanged Body Flowmeters; Integral Mount; Single Measurement — Dimensions

Dimension	Dimensions - Nominal Line Size Code ^(a)									
	3Q	01	1H	02	03	04	06	08	10 ^(b)	12 ^(b)
A	$\frac{205}{8.1}$	$\frac{205}{8.1}$	$\frac{205}{8.1}$	$\frac{205}{8.1}$	$\frac{205}{8.1}$	$\frac{205}{8.1}$	$\frac{205}{8.1}$	$\frac{205}{8.1}$	$\frac{205}{8.1}$	$\frac{205}{8.1}$
B	$\frac{306}{12}$	$\frac{306}{12}$	$\frac{306}{12}$	$\frac{306}{12}$	$\frac{306}{12}$	$\frac{306}{12}$	$\frac{306}{12}$	$\frac{306}{12}$	$\frac{306}{12}$	$\frac{306}{12}$
C ^(c)	Dimension C varies with flange type, rating, and size used. See Table 6 and Table 7 further in document for dimensions.									

(a) Also, refer to DP 019-125 and DP 019-126 for 84F (Style B) dimensions.

(b) Dimensions A and B are shown with the standard temperature bonnet with extended temperature applications, add 3.6 in (91.4 mm) to Dimensions A and B because of the longer bonnet.

(c) Dimension C is a face-to-face dimension.

(d) Refer to the Model Code section for sizes.

DIMENSIONS – NOMINAL (CONT.)

**mm
in**

84F (Style B) FLANGED FLOWMETER; INTEGRAL MOUNT; DUAL MEASUREMENT

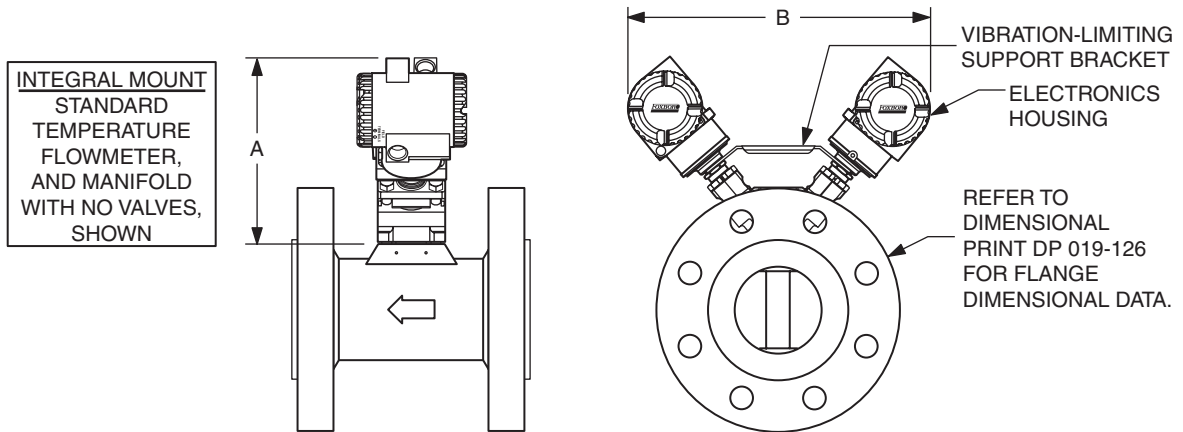

Integral Mount Dimensions

Dimension	Standard Temperature Flowmeter		Extended Temperature Flowmeter	
	No Isolation Valves	With Isolation Valves	No Isolation Valves	With Isolation Valves
A	8.6 in (218 mm)	9.3 in (236 mm)	11.4 in (290 mm)	12.1 in (307 mm)
B	15.4 in (391 mm)	19.4 in (493 mm)	20.0 in (508 mm)	24.0 in (610 mm)

84F (Style B) FLANGED FLOWMETER; REMOTE MOUNT; DUAL MEASUREMENT

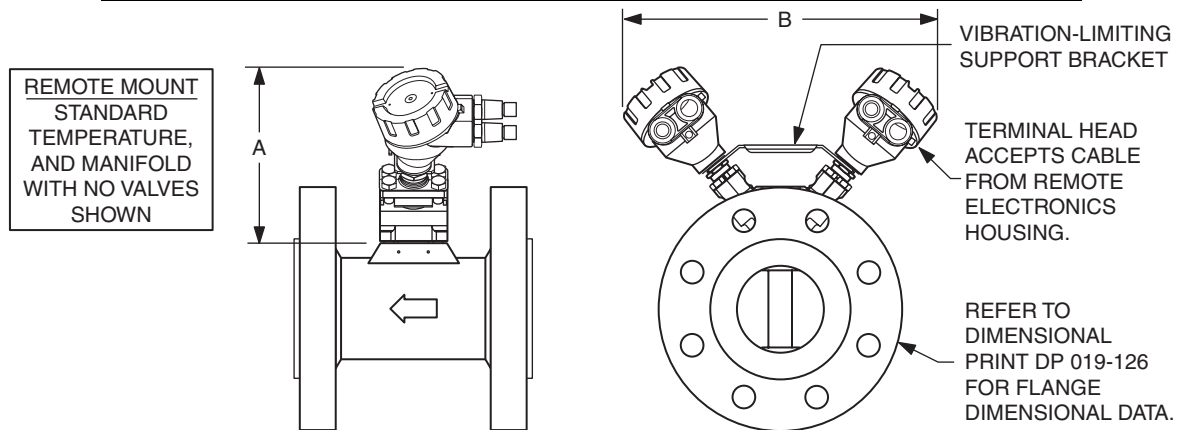

Remote Mount Dimensions

Dimension	Standard Temperature Flowmeter		Extended Temperature Flowmeter	
	No Isolation Valves	With Isolation Valves	No Isolation Valves	With Isolation Valves
A	7.8 in (198 mm)	8.9 in (226 mm)	11.4 in (290 mm)	12.1 in (307 mm)
B	15.4 in (391 mm)	19.4 in (493 mm)	20.0 in (508 mm)	24.0 in (610 mm)

(a) Also refer to DP 019-125 for further dimensions.

DIMENSIONS – NOMINAL (CONT.)

$\frac{\text{mm}}{\text{in}}$

84F (Style B) FLANGED BODY FLOWMETERS WITH REMOTE MOUNTED ELECTRONICS

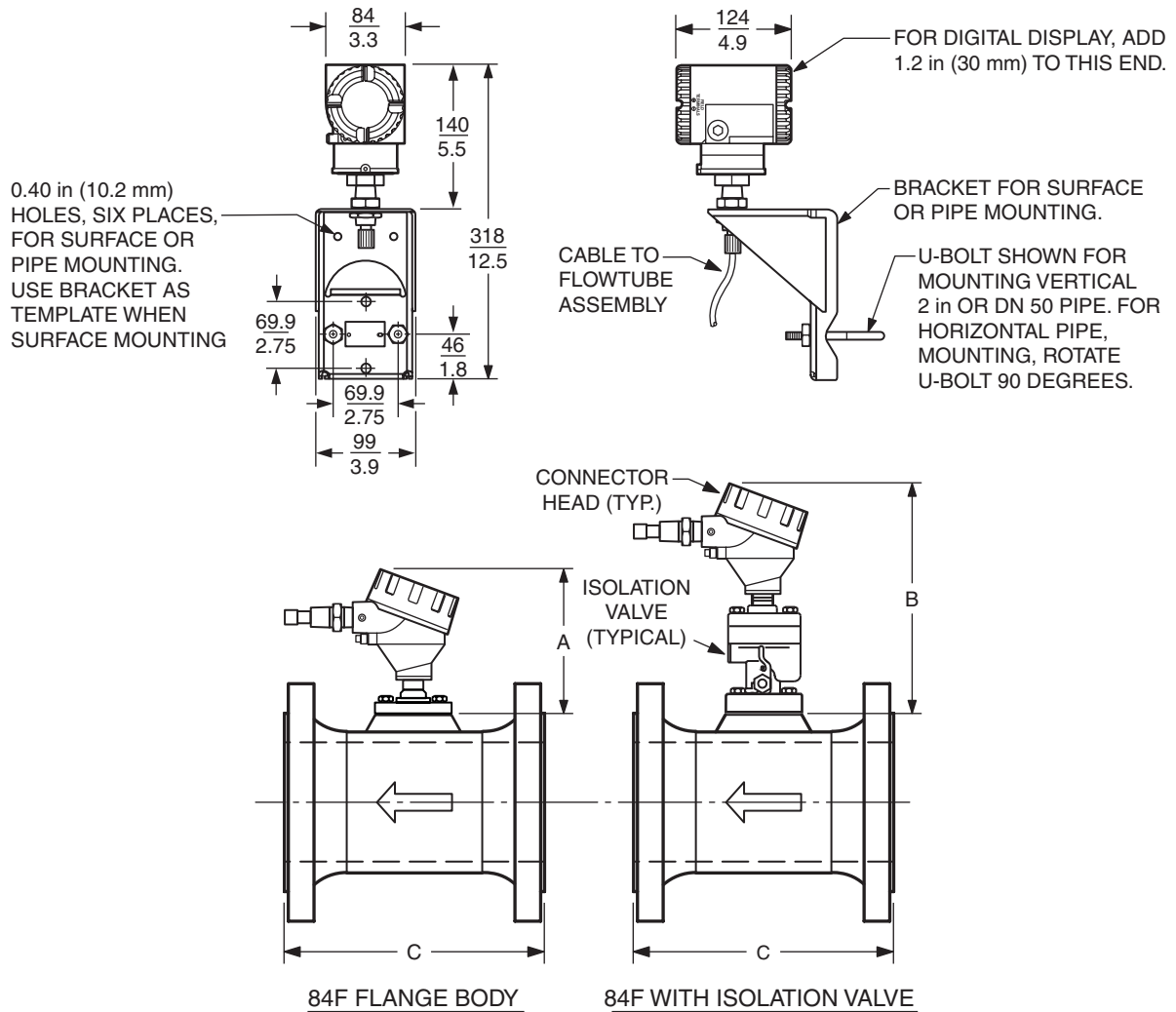

DIMENSIONS – NOMINAL (CONT.)

84F (Style B) Flanged Body Flowmeters With Remote Mounted Electronics (Cont.)

Dimension	Dimensions - Nominal Line Size Code ^(a)									
	3Q	01	1H	02	03	04	06	08	10 ^(b)	12 ^(b)
A	$\frac{205}{8.0}$	$\frac{205}{8.0}$	$\frac{205}{8.0}$	$\frac{205}{8.0}$	$\frac{205}{8.0}$	$\frac{205}{8.0}$	$\frac{205}{8.0}$	$\frac{205}{8.0}$	$\frac{205}{8.0}$	$\frac{205}{8.0}$
B	$\frac{306}{12}$	$\frac{306}{12}$	$\frac{306}{12}$	$\frac{306}{12}$	$\frac{306}{12}$	$\frac{306}{12}$	$\frac{306}{12}$	$\frac{306}{12}$	$\frac{306}{12}$	$\frac{306}{12}$
C ^(c)	Dimension C varies by with flange type, rating, and size used. See Table 6 and Table 7 further in document for dimensions.									

- (a) Also, refer to DP 019-125 and DP 019-126 for 84F (Style B) dimensions.
- (b) Dimensions A and B are shown with the standard temperature bonnet with extended temperature applications, add 3.6 in (91.4 mm) to Dimensions A and B because of the longer bonnet.
- (c) Dimension C is a face-to-face dimension.
- (d) Refer to the Model Code section for sizes.

Before installing your flowmeter, check its data plate to determine whether it is Style A or Style B. The style indicator (ST) on the data plate is illustrated below for a Style A flowmeter.

The face-to-face given in Table 8 and Table 9 correspond to Model 84 Style A flowmeters, and the face-to-face given in Table 6 and Table 7 correspond to Model 84 Style B flowmeters.

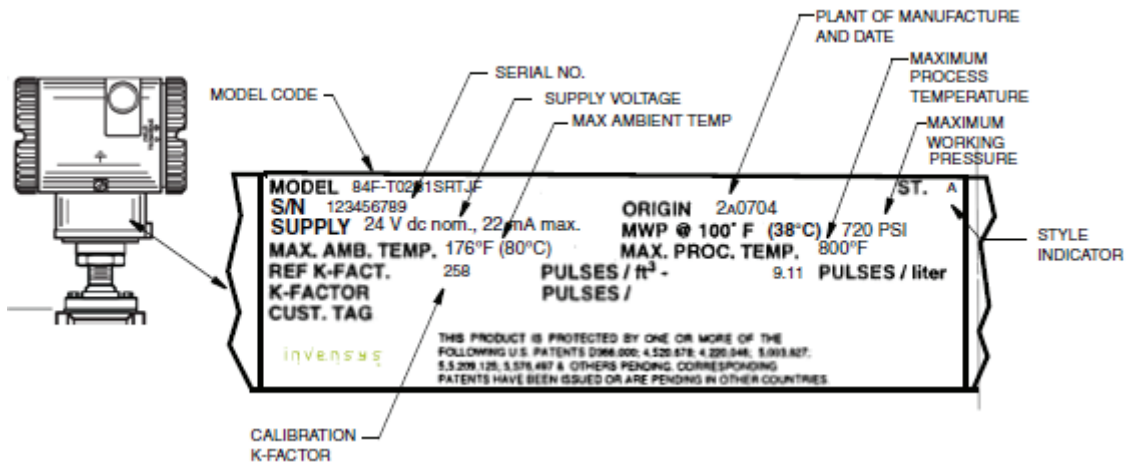

Table 6. 84F Single Measurement Configuration With ANSI Flanges and With Integral Housing Body, Flange, and Shedder Bar Material Model Code Options R, J, D, and H

Nominal Line Size	Flange Type	Dimensions in inches				
		A (O.D.)	B (I.D.)	C ^(a) RF	C ^(a) RTJ	F
3/4 in	Class 150	3.88	0.74	6.56	--	1.82
	Class 300	4.62	0.74	6.94	7.32	1.82
	Class 600	4.62	0.74	7.44	7.44	1.82
	Class 900	5.12	0.74	8.44	8.44	1.82
	Class 1500	5.12	0.74	8.44	8.44	1.82
1 in	Class 150	4.25	0.96	6.80	7.18	1.93
	Class 300	4.88	0.96	7.32	7.70	1.93
	Class 600	4.88	0.96	7.82	7.82	1.93
	Class 900	5.88	0.96	8.7	8.70	1.93
	Class 1500	5.88	0.96	8.7	8.70	1.93
1 1/2 in	Class 150	4.62	1.50	7.32	7.70	2.20
	Class 300	6.12	1.50	7.82	8.20	2.20
	Class 600	6.12	1.50	8.44	8.44	2.20
	Class 900	7.00	1.50	9.44	9.44	2.20
	Class 1500	7.00	1.50	9.44	9.44	2.20
2 in	Class 150	6.00	1.94	7.75	8.13	2.32
	Class 300	6.50	1.94	8.25	8.75	2.32
	Class 600	6.50	1.94	9.01	9.13	2.32
	Class 900	8.50	1.94	11.25	11.37	2.32
	Class 1500	8.50	1.69	11.25	11.37	2.20
3 in	Class 150	7.50	2.87	8.88	9.26	2.75
	Class 300	8.25	2.87	9.62	10.12	2.75
	Class 600	8.25	2.87	10.38	10.50	2.75
	Class 900	9.50	2.87	11.88	12.00	2.75
	Class 1500	10.50	2.63	13.12	13.25	2.62

Table 6. 84F Single Measurement Configuration With ANSI Flanges and With Integral Housing Body, Flange, and Shedder Bar Material Model Code Options R, J, D, and H (Continued)

Nominal Line Size	Flange Type	Dimensions in inches				
		A (O.D.)	B (I.D.)	C ^(a) RF	C ^(a) RTJ	F
4 in	Class 150	9.00	3.83	9.62	10.00	3.35
	Class 300	10.00	3.83	10.38	10.88	3.35
	Class 600	10.75	3.83	12.12	12.24	3.35
	Class 900	11.50	3.83	13.12	13.24	3.35
	Class 1500	12.25	3.44	13.88	14.00	3.35
6 in	Class 150	11.00	5.76	12.00	12.38	4.42
	Class 300	12.50	5.76	12.76	13.26	4.42
	Class 600	14.00	5.76	14.74	14.86	4.42
	Class 900	15.00	5.19	16.5	16.62	4.42
	Class 1500	15.50	5.19	19.00	19.25	4.42
8 in	Class 150	13.50	7.63	15.00	15.38	5.47
	Class 300	15.00	7.63	15.75	16.26	5.47
	Class 600	16.50	7.63	18.00	18.12	5.47
	Class 900	18.50	6.81	20.26	20.38	5.47
	Class 1500	19.00	6.81	24.26	24.64	5.47
10 in	Class 150	16.00	9.56	15.00	15.38	6.55
	Class 300	17.50	9.56	16.24	16.74	6.55
	Class 600	20.00	9.56	19.5	19.62	6.55
12 in	Class 150	19.00	11.37	17.00	17.38	7.55
	Class 300	20.50	11.37	18.24	18.74	7.55
	Class 600	22.00	11.37	20.74	20.76	7.55

(a) Overall length "C" is ± 0.250 in (± 6.4 mm).

Table 7. 84F Single Measurement Configuration With DIN Flanges and With Integral Housing Body, Flange, and Shedder Bar Material Model Code Options R, J, D, and H

Nominal Line Size	Flange Type	Dimensions in mm			
		A (O.D.)	B (I.D.)	C ^(a)	F
15 mm	PN 40 ^(b)	95.00	18.80	138.00	46.20
	PN 100	105.00	18.80	152.00	46.20
25 mm	PN 40 ^(b)	115.00	24.31	142.00	49.00
	PN 100	140.00	24.31	178.00	49.00
	PN 160	140.00	24.31	178.00	49.00
40 mm	PN 40 ^(b)	150.00	38.10	152.00	55.90
	PN 100	170.00	38.10	186.00	55.90
	PN 160	170.00	38.10	190.00	55.90
50 mm	PN 40 ^(b)	165.00	49.20	166.00	58.90
	PN 63	180.00	49.20	194.00	58.90
	PN 100	195.00	49.20	206.00	58.90
	PN 160	195.00	49.20	220.00	58.90
80 mm	PN 40 ^(b)	200.00	72.90	202.00	69.90
	PN 63	215.00	72.90	230.00	69.90
	PN 100	230.00	72.90	242.00	69.90
	PN 160	230.00	72.90	258.00	69.90
100 mm	PN 40 ^(b)	235.00	97.18	222.00	85.10
	PN 63	250.00	97.18	248.00	85.10
	PN 100	265.00	97.18	272.00	85.10
	PN 160	265.00	97.18	292.00	85.10
150 mm	PN 16	285.00	146.30	237.00	112.30
	PN 40 ^(b)	300.00	146.30	277.00	112.30
	PN 63	345.00	146.30	317.00	112.30
	PN 100	355.00	146.30	357.00	112.30
	PN 160	355.00	131.80	383.00	112.30

Table 7. 84F Single Measurement Configuration With DIN Flanges and With Integral Housing Body, Flange, and Shedder Bar Material Model Code Options R, J, D, and H (Continued)

Nominal Line Size	Flange Type	Dimensions in mm			
		A (O.D.)	B (I.D.)	C ^(a)	F
200 mm	PN 16	340.00	193.68	302.00	138.90
	PN 25	360.00	193.68	338.00	138.90
	PN 40	375.00	193.68	354.00	138.90
	PN 63	415.00	193.68	398.00	138.90
	PN 100	430.00	193.68	438.00	138.90
	PN 160	430.00	173.05	458.00	138.90
250 mm	PN 16	405.00	242.87	318.00	166.40
	PN 25	425.00	242.87	354.00	166.40
	PN 40	450.00	242.87	388.00	166.40
	PN 63	470.00	242.87	428.00	166.40
	PN 100	505.00	242.87	492.00	166.40
300 mm	PN 16	460.00	288.90	359.00	191.80
	PN 25	485.00	288.90	387.00	191.80
	PN 40	515.00	288.90	433.00	191.80
	PN 63	530.00	288.90	483.00	191.80
	PN 100	585.00	288.90	543.00	191.80

(a) Overall length "C" is ± 0.250 in (± 6.4 mm).

(b) May be used with PN 25 mating flange.

Table 8. 84F Single Measurement Configuration With ANSI Flanges and With Integral Housing Body, Flange, and Shedder Bar Material Model Code Option Y (Backward compatible with Style A)

(Note: These versions should only be used when replacing a Model 84F Style A meter or for stocking purposes for Model 84F Style A meters.)					
Nominal Line Size	Flange Rating	Dimensions in inches			
		A (O.D.)	B (I.D.)	C ^(a)	F
3/4 in	Class 150	3.88	0.74	6.00	1.82
	Class 300	4.62	0.74	6.00	
	Class 600	4.62	0.74	6.50	
1 in	Class 150	4.25	0.96	6.50	1.93
	Class 300	4.88	0.96	6.50	
	Class 600	4.88	0.96	7.00	
1 1/2 in	Class 150	4.62	1.50	7.25	2.20
	Class 300	6.12	1.50	7.25	
	Class 600	6.12	1.50	7.88	
2 in	Class 150	6.00	1.94	7.75	2.32
	Class 300	6.50	1.94	7.75	
	Class 600	6.50	1.94	8.50	
3 in	Class 150	7.50	2.87	8.75	2.75
	Class 300	8.25	2.87	8.75	
	Class 600	8.25	2.87	9.50	
4 in	Class 150	9.00	3.83	9.50	3.35
	Class 300	10.00	3.83	9.50	
	Class 600	10.75	3.83	10.50	
6 in	Class 150	11.00	5.76	12.00	4.42
	Class 300	12.50	5.76	12.75	
	Class 600	14.00	5.76	14.75	
8 in	Class 150	13.50	7.63	15.00	5.47
	Class 300	15.00	7.63	15.75	
	Class 600	16.50	7.63	18.00	

Table 8. 84F Single Measurement Configuration With ANSI Flanges and With Integral Housing Body, Flange, and Shedder Bar Material Model Code Option Y (Backward compatible with Style A) (Continued)

(Note: These versions should only be used when replacing a Model 84F Style A meter or for stocking purposes for Model 84F Style A meters.)					
Nominal Line Size	Flange Rating	Dimensions in inches			
		A (O.D.)	B (I.D.)	C ^(a)	F
10 in	Class 150	16.00	9.56	15.00	6.55
	Class 300	17.50	9.56	16.20	
12 in	Class 150	19.00	11.37	17.00	7.55
	Class 300	20.50	11.37	18.20	

(a) Overall length "C" is ± 0.250 in (± 6.4 mm).

NOTE

Style B Vortex flowmeters with ANSI flanges contain a model code option for face-to-face lengths that are backward compatible with Style A Vortex flowmeters. Style B model code selection "Y" matches Style A model code selection "S".

The majority of Style B DIN flanges have shorter face-to-face lengths than those of Style A. Contact Invensys for backward compatibility of DIN face-to-face lengths.

Table 9. Style A Face-to-Face Lengths for DIN Flanges

(Note: These versions should only be used when replacing a Model 84F Style A meter or for stocking purposes for Model 84F Style A meters.)					
Nominal Line Size	Flange Type	Dimensions in mm			
		A (O.D.)	B (I.D.)	C ^(a)	F
15 mm	PN 40 ^(b)	95.00	18.80	152.00	46.20
	PN 100	105.00	18.80	160.00	46.20
25 mm	PN 40 ^(b)	115.00	24.31	166.00	49.00
	PN 100	140.00	24.31	178.00	49.00
40 mm	PN 40 ^(b)	150.00	38.10	179.00	55.90
	PN 100	170.00	38.10	199.00	55.90
50 mm	PN 40 ^(b)	165.00	49.20	193.00	58.90
	PN 63	180.00	49.20	202.00	58.90
	PN 100	195.00	49.20	211.00	58.90
80 mm	PN 40 ^(b)	200.00	72.90	220.00	69.90
	PN 63	215.00	72.90	230.00	69.90
	PN 100	230.00	72.90	242.00	69.90
100 mm	PN 40 ^(b)	235.00	97.18	240.00	85.10
	PN 63	250.00	97.18	250.00	85.10
	PN 100	265.00	97.18	268.00	85.10
150 mm	PN 16	285.00	146.30	305.00	112.30
	PN 40 ^(b)	300.00	146.30	320.00	112.30
	PN 63	345.00	146.30	360.00	112.30
	PN 100	355.00	146.30	360.00	112.30
200 mm	PN 16	340.00	193.68	351.00	138.90
	PN 40	375.00	193.68	396.00	138.90
	PN 63	415.00	193.68	443.00	138.90
	PN 100	430.00	193.68	443.00	138.90

Table 9. Style A Face-to-Face Lengths for DIN Flanges (Continued)

(Note: These versions should only be used when replacing a Model 84F Style A meter or for stocking purposes for Model 84F Style A meters.)					
Nominal Line Size	Flange Type	Dimensions in mm			
		A (O.D.)	B (I.D.)	C ^(a)	F
250 mm	PN 16	405.00	242.87	316.00	166.40
	PN 40	450.00	242.87	408.00	166.40
	PN 63	470.00	242.87	481.00	166.40
300 mm	PN 16	460.00	288.90	358.00	191.80
	PN 40	515.00	288.90	461.00	191.80
	PN 63	530.00	288.90	513.00	191.80

- (a) Overall length "C" is ± 0.250 in (± 6.4 mm).
(b) May be used with PN 25 mating flange.

ORDERING INSTRUCTIONS

1. Model Number.
2. Flow Data:
 - a. Maximum, minimum, and normal flow rate.
 - b. Fluid composition and viscosity at operating temperatures.
 - c. Fluid density or relative density (specific gravity).
 - d. Maximum, minimum, and normal operating temperatures.
 - e. Maximum, minimum, and normal operating pressures.
 - f. Mating pipe schedule.
 - g. Type and location (distance) of upstream disturbances.
3. Calibration Information (analog output only); maximum flow rate at 20 mA output.
4. Electrical Classification.
5. Optional Selections and Accessories
Select from Model Code or the "Optional Selections and Accessories" section
6. Customer Tag Data.

OTHER M&I PRODUCTS

Invensys provides a broad range of measurement and instrument products, including solutions for pressure, flow, analytical, positioners, temperature, controlling and recording. For a listing of these offerings, visit the Invensys Operations Management web site at: www.iom.invensys.com

Invensys Operations Management
5601 Granite Parkway Suite 1000
Plano, TX 75024
United States of America
<http://iom.invensys.com>

Global Customer Support
Inside U.S.: 1-866-746-6477
Outside U.S.: 1-508-549-2424 or contact
your local Invensys representative.
Website: <http://support.ips.invensys.com>

Invensys, Foxboro, FoxCom, and I/A Series are trademarks of Invensys plc, its subsidiaries, and affiliates.
All other brand names may be trademarks of their respective owners.

Copyright 2011-2012 Invensys Systems, Inc.
All rights reserved

MB 010

0212